

Phonics

# Letter of the Week



Bb

Lavinia Pop

**Thank you** for downloading this product; I hope you will enjoy using it and that it will be a valuable resource for you! I value your feedback, so please don't hesitate to contact me if you have any concerns whatsoever as I will endeavour to address them. And if you like what I've done, please let me know by leaving feedback at my online store :)

*Lavinia*

[lavinia@inmyworld.com.au](mailto:lavinia@inmyworld.com.au)

ILLUSTRATIONS Just So Scrappy 2, Pink Cat Studio, TeacherScrapbook, Little Red, Jessica Weible Illustrations, Dancing Crayon Designs, Ink 'n Little Things, Ramona Majdis, Kari Bolt

[www.justsoscrappytoo.com](http://www.justsoscrappytoo.com)   [www.pinkcatstudio.com](http://www.pinkcatstudio.com)   [www.teacherspayteachers.com/Store/Teacherscrapbook](http://www.teacherspayteachers.com/Store/Teacherscrapbook)  
[www.teacherspayteachers.com/Store/Littlered](http://www.teacherspayteachers.com/Store/Littlered)   [www.shopjwillustrations.com](http://www.shopjwillustrations.com)   [www.dancingcrayon.com](http://www.dancingcrayon.com)  
[www.teacherspayteachers.com/Store/Ink-N-Little-Things](http://www.teacherspayteachers.com/Store/Ink-N-Little-Things)   [www.teacherspayteachers.com/Store/Ramona-Majdis](http://www.teacherspayteachers.com/Store/Ramona-Majdis)  
[www.teacherspayteachers.com/Store/Kari-Bolt](http://www.teacherspayteachers.com/Store/Kari-Bolt)

FONTS [www.schoolfonts.com.au](http://www.schoolfonts.com.au)

PRINTING TIP: This resource has been designed for printing on A4-sized paper. If you are printing on a different size, select "shrink to printable area" or "print to fit page" (or a similar option) in order for the contents of this unit to print correctly.

Copyright © 2013–2014 by Lavinia Pop – All rights reserved by author.

Purchase of this item entitles the purchaser the right to reproduce the pages for personal and classroom use. Duplication for other classes, an entire school or commercial purposes is strictly prohibited without written permission from the author. Minor editing is permitted only for personal use, however the document remains under copyright even when edited. Posting this item in whole or in part on the Internet in any form is strictly prohibited and is a violation of the Digital Millennium Copyright Act (DMCA). Please be fair and don't share! If you are not the original purchaser of this file, please visit my blog to obtain a link to one of my online stores. [www.inmyworld.com.au](http://www.inmyworld.com.au)

Click to connect...



[www.inmyworld.com.au](http://www.inmyworld.com.au)



[www.facebook.com/inmyworldlavinipop](http://www.facebook.com/inmyworldlavinipop)



[www.pinterest.com/lavinipop](http://www.pinterest.com/lavinipop)

# Contents

Introduction	4-8
Poster with correct letter formation	9
Poster with CVC words	10
Flash cards with correct letter formation	11
Play dough mat with correct letter formation	12
Write and wipe cards with correct letter formation	13
Write and wipe letter mat	14
Vocabulary cards	15-18
Doggie, Where's the Sound? game	19-24
Build-a-sentence center	25-26
Letter flip book	27-30
Activity mini-book	31
Alphabet reader	32-43
Missing letter cut and paste reader	44-51
Picture scramble cut and paste booklet	52-59
Letter maze	60
Font discrimination maze	61
Hidden letter worksheet (2 sets)	62-63
Beginning sounds colouring worksheet	64
Letter find	65
Handwriting practice	66-67
Upper and lower case cut and paste	68-69
Beginning sounds cut and paste	70-71
CVC words cut and paste	72-73
CVC word match	74
Letter identification worksheet	75
Build-a-sentence cut and paste worksheet (set of 5)	76-80
Homework reading sheet	81
Alphabet crown	82-84
Letter craft	85-86

# Introduction

## About this book:

This Phonics Letter of the Week unit has been designed to be used with children in Kindergarten (Prep). It contains a variety of games, activities and worksheets that will help teach correct letter formation, letter identification and recognition of letter sound.

The purpose of creating the Phonics Letter of the Week series, in which this unit belongs, was to provide a means by which one letter of the alphabet could be taught at a time. A great emphasis is placed on letter sounds, which makes this an ideal tool for teaching phonics.

## Directions for use:

Before you begin...

Have the children say out loud the sound of the letter each time they work on a tracing worksheet; this will reinforce the relationship between the letter and the sound it makes. In addition to this, children will remember the sounds as they begin to read later on, and those that have trouble with reversals (such as the letters "b" and "d"), will remember that "b" starts at the top and "d" starts at the circle.

Following is an outline of what you will find in this book and suggestions for implementing the content in your classroom.

### 1. Poster with correct letter formation

To set up the poster for use, print, laminate and display on your wall.

### 2. Poster with CVC words

This poster displays 10 CVC words that either begin with or contain the letter in focus. To set up, print laminate and display on your wall or include it in a file-folder word wall.

### 3. Flash cards with correct letter formation

These cards display correct letter formation for both upper and lower case letters. They can be used as flash cards, tracing cards or even displayed as posters. To prepare the cards for use, print them out, laminate for durability and then cut them apart (optional).

### 4. Play dough mat with correct letter formation

Children will have lots of fun using play dough to reproduce the letters on the mat! They will learn correct letter formation and build up their fine motor skills in preparation for writing. To set up, print and laminate. (Cut in half if you want separate cards).



### 5. Write and wipe cards with correct letter formation

Children can practice correct letter formation over and over with these cards, using a dry-erase marker. To set up, print, laminate and cut out. To keep the cards together, make a hole in the top left hand corner and secure with a key ring or pipe cleaner.

### 6. Write and wipe letter mat

This mat has been designed for use in a Write and Wipe center with a dry-erase marker. Children trace both upper and lower case letters, a word that begins with the letter in focus, and 5 CVC words that begin with or contain the letter in focus. To set up, print and laminate.

### 7. Vocabulary cards

This set contains 18 vocabulary cards that begin with the letter in focus and 9 cards that contain or end with the letter in focus. These can be used as:

- vocabulary flash cards
- a matching game (for which you will need to print 2 sets)

To set up, print, laminate and cut the cards apart.

I have also included a Write the Room activity worksheet. Children write down as many "letter in focus" words they see in the classroom.

### 8. Doggie, Where's the Sound?

Set-Up: Print, laminate and cut out the dog you prefer to use and the picture cards. Cut the doggie down the dotted lines to separate the head, middle and tail sections.

Each card displays a picture with the letter in focus above it. The aim is for children to identify the position of the letter (beginning/head; middle/tummy or end/tail) as they say each word, and place the cards under the corresponding doggie section. They then complete the accompanying worksheet (please note this can be used independently of the activity).

### 9. Build-a-sentence

Set-Up: Print the contents of page 25 and laminate for durability. Cut out the sentence base (entire first row) and along the dotted lines of the picture cards to obtain 8 squares. You may store these in a large zip-lock bag.

The aim of this game is to practice reading a predictable sentence using different vocabulary words that begin with the letter in focus. Children choose a picture card from the pile and place it over the coloured square on the sentence frame, then read the sentence out loud. I have included a recording sheet children can do upon completion of the activity.

### 10. Letter flip book

Set-Up: Assembly is required, either by teacher or students. You will need to cut around each rectangle box, then along the dashed lines of the bottom one. Make sure that the top rectangle is left intact as it will form the base for the flip book! Arrange the word cards one on top of the other and staple them to the base. Students will have lots of fun reading their books over and over again to friends and family! I have included a couple of recording sheets for this activity.

### 11. Activity mini book

A foldable mini-book with different activities: letter identification, beginning sounds and letter tracing. Simply fold the page vertically down the middle and then horizontally to create the book

### 12. Alphabet reader

Set-Up: I have included 2 versions of this activity: black and white and coloured. Once you have selected your preferred version, print, then either teacher or student will need to cut each page in half and staple on the left hand margin to form a book. Children practice reading a predictable sentence that uses the most common sight words and simple words (mostly CVC) that begin with the letter in focus.

### 13. Missing letter cut and paste reader

Set-Up: Place each page (44-50) on top of each other in order, cut in half and staple to make 2 booklets. Also cut the last page (51) so that you will get 3 strips of 6 letter pairs. Children are required to cut the 6 pairs apart and paste one on each page of their booklet, and then read the sentence on the page.

### 14. Picture scramble cut and paste booklet

Set-Up: Print the pages, stack them on top of each other and cut in half to form 2 booklets. Staple each one. Print the end picture-tile page and leave as is – children will cut these tiles apart and build the words inside their booklets with them. Once all the words have been built, the right hand column on each page may be completed by colouring the word, tracing it, then writing it.

### 15. Letter maze

Children complete this worksheet by colouring the squares that contain the letter in focus. The aim is to make a pathway from one end of the maze to the other.

### 16. Font discrimination maze

Children complete this worksheet by colouring the circles that contain the letter in focus. The aim of this worksheet is to help children recognise the focus letter written in different fonts.

### 17. Hidden letter worksheet (2 sets)

Children reveal the hidden letter by colouring each section using the colours indicated at the bottom of the page.

### 18. Beginning sounds colouring worksheet

Children colour in the pictures which begin with the sound of the letter in focus.

### 19. Letter Find

Children search for both upper and lower case letters, then write the number of times each was found in the circles on the left hand side.

## 20. Handwriting practice

Children practice writing both upper and lower case letters.

## 21. Upper and lower case cut and paste

The main focus of this worksheet is on lower and upper case letter identification. Children trace the letters, write them in the boxes, cut the requested letter tiles from the bottom of the page and paste them in the section provided.

## 22. Beginning sounds cut and paste

Children begin this worksheet by tracing the letter in focus, then cutting the picture tiles at the bottom of the page and pasting them next to their correct beginning sound.

## 23. CVC words cut and paste

Children read the words in the left hand column and then trace them. To demonstrate comprehension, they are required to cut the pictures from the bottom of the page and paste next to the correct word. Finally, they write the words in the right hand column.

## 24. CVC word match

Children read the words in the left column, write them on the lines, and then match them to the correct picture.

## 25. Letter identification worksheet

Children underline the lower case letters in the given words, then both upper and lower case letters in the nursery rhyme at the bottom of the page. They then write how many focus letters were found.

## 26. Build-a-sentence cut and paste worksheet (set of 5)

Children begin this worksheet by reading a simple sentence, writing it, then cutting and pasting the words from the bottom of the page, in correct order, to form the sentence. (This set contains the same wording as in the reader.)

## 27. Homework reading sheet

This homework sheet focuses solely on letter sounds. For writing homework, chose any of the other worksheets included in this pack.

## 28. Alphabet crown

The crown can be completed at the end of the week as an “I know the letter!” achievement activity. Children cut out their crowns on the cutting line or around the solid shape. They also cut out the shapes containing 3 pictures and glue them onto their crowns. I have also included letter tracing head wraps that can be secured to each side of the crown to form the back part of it. Usage of this is optional; students could use string instead to tie to the crown so it will sit on their heads.

## 29. Letter craft

These two pages contain blank upper and lower case letter templates that you can use with children to create letter activities and crafts. Please visit my blog for ideas on how to use them:

[www.inmyworld.com.au/category/preschool](http://www.inmyworld.com.au/category/preschool)

Happy Teaching :)

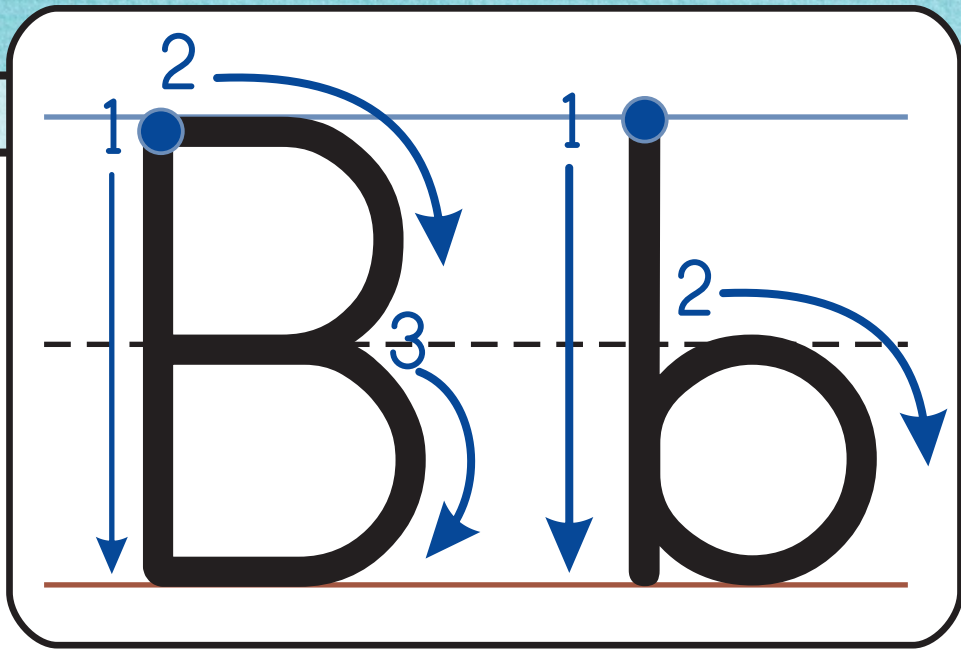

bed



# Bb

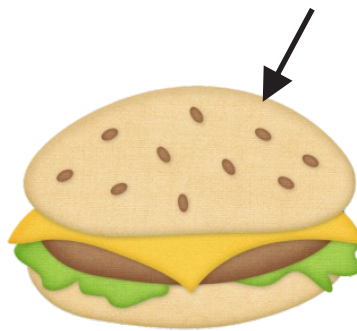

bag

bat

bus

bed

beg

big

bin

box

bug

bun

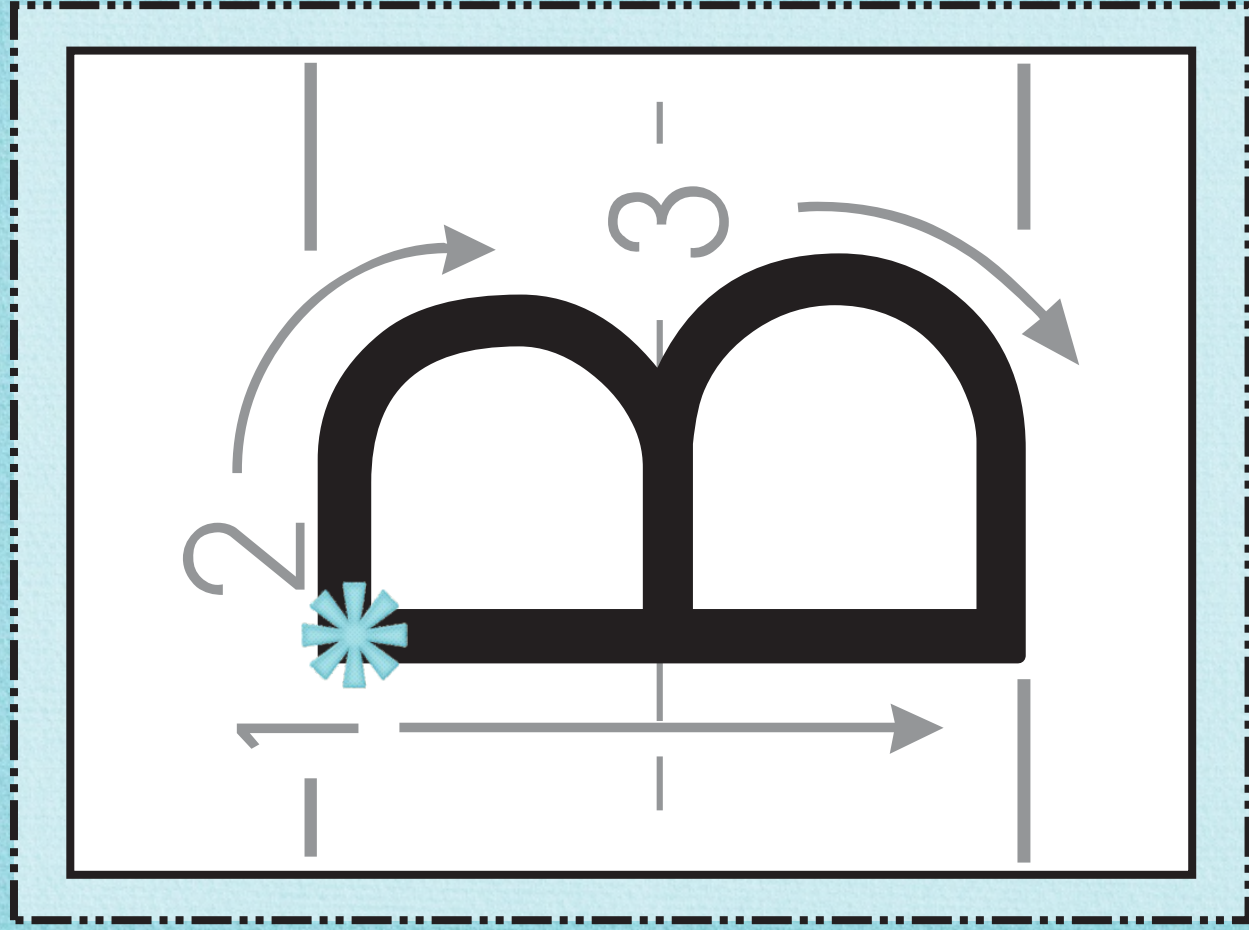
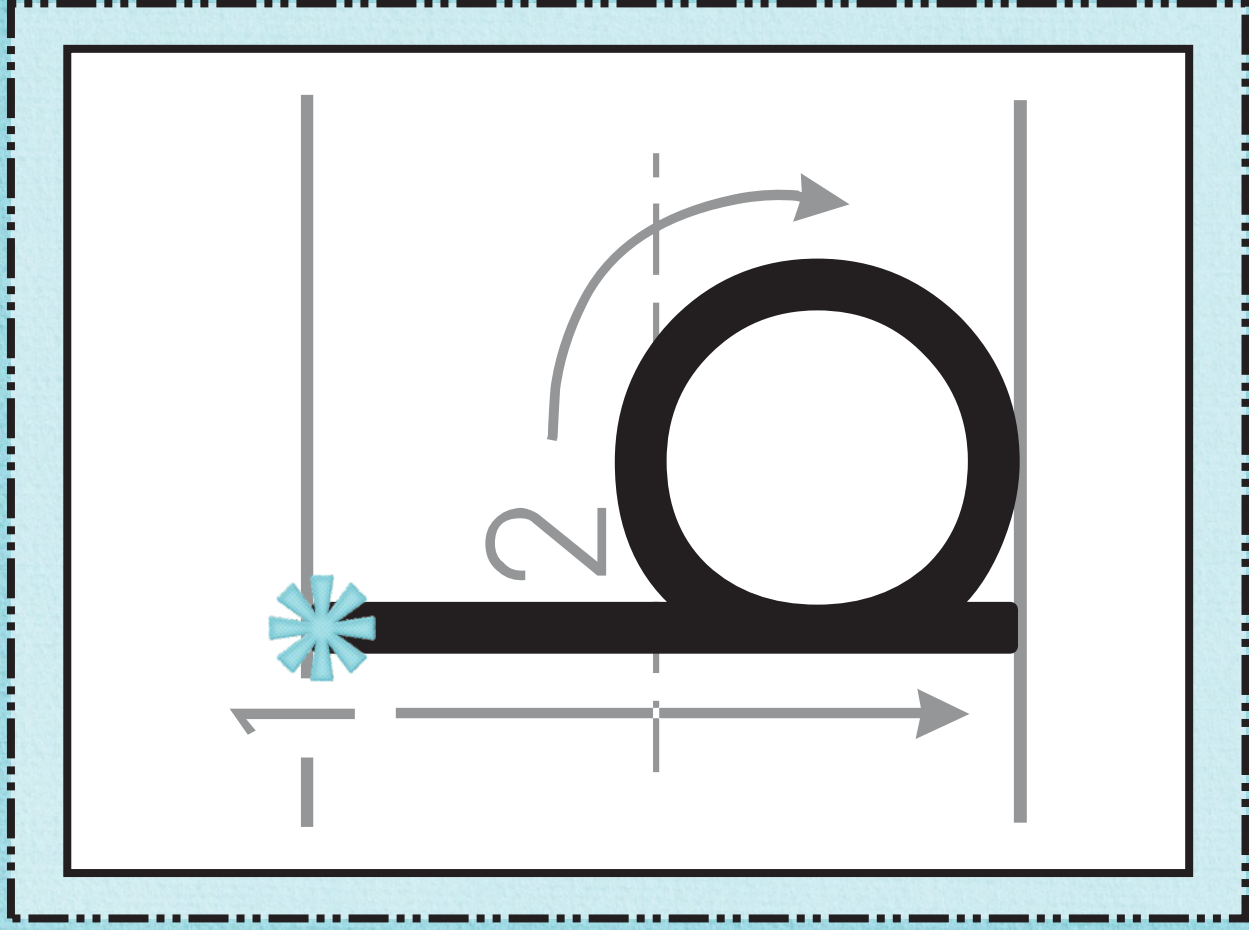



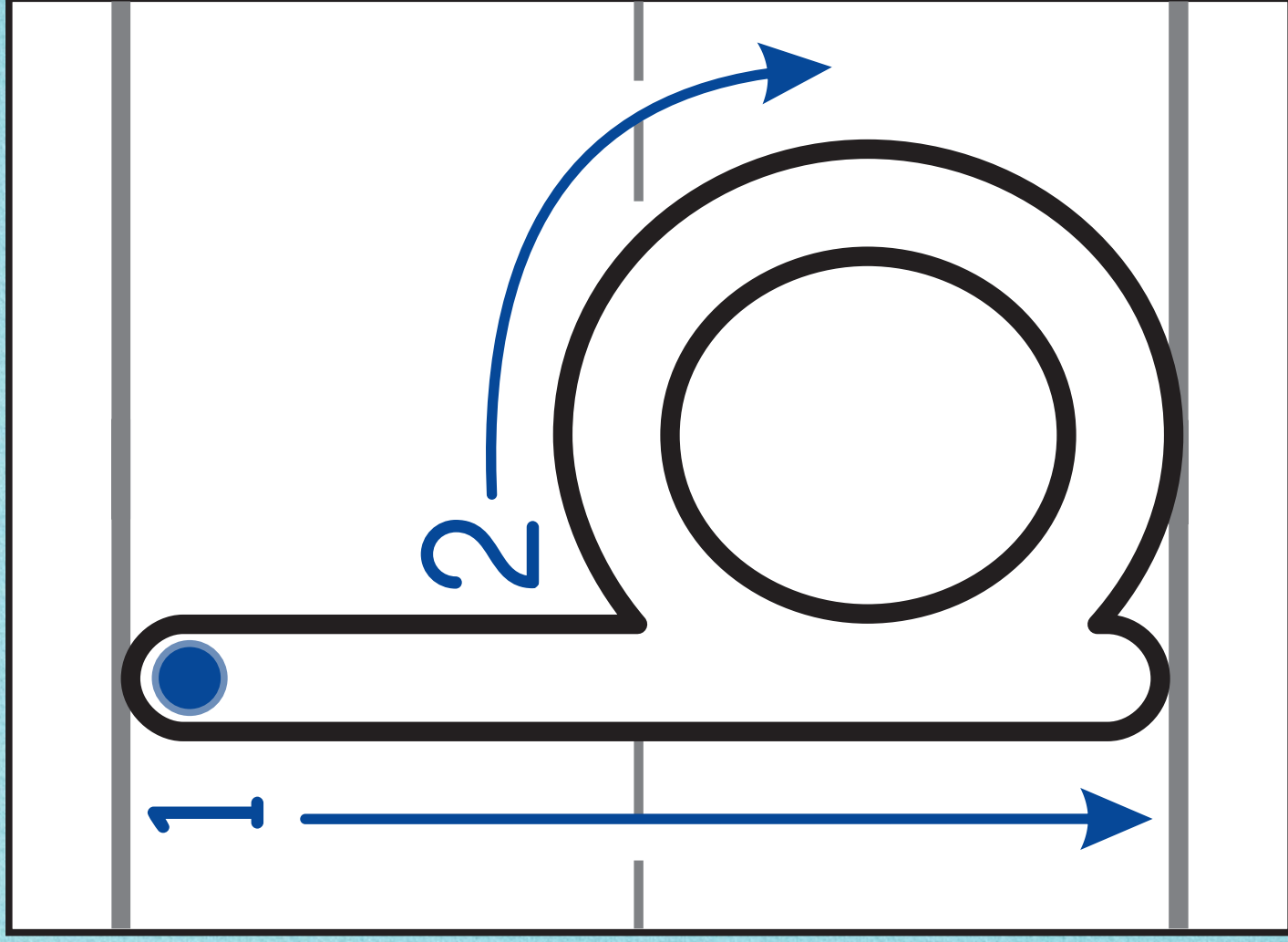
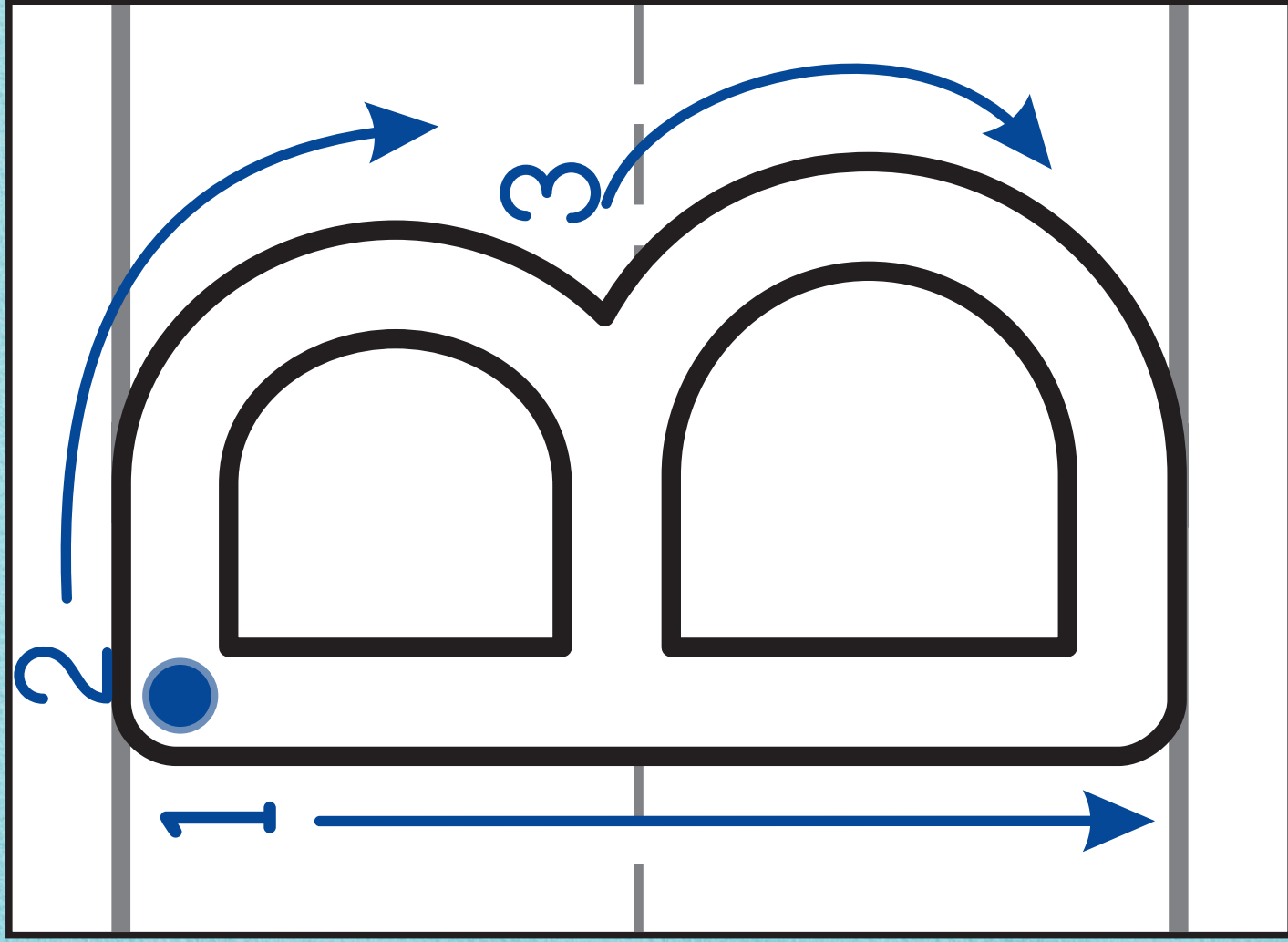

Lavinia Pop © 2013

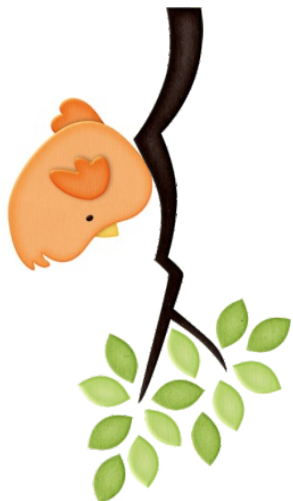
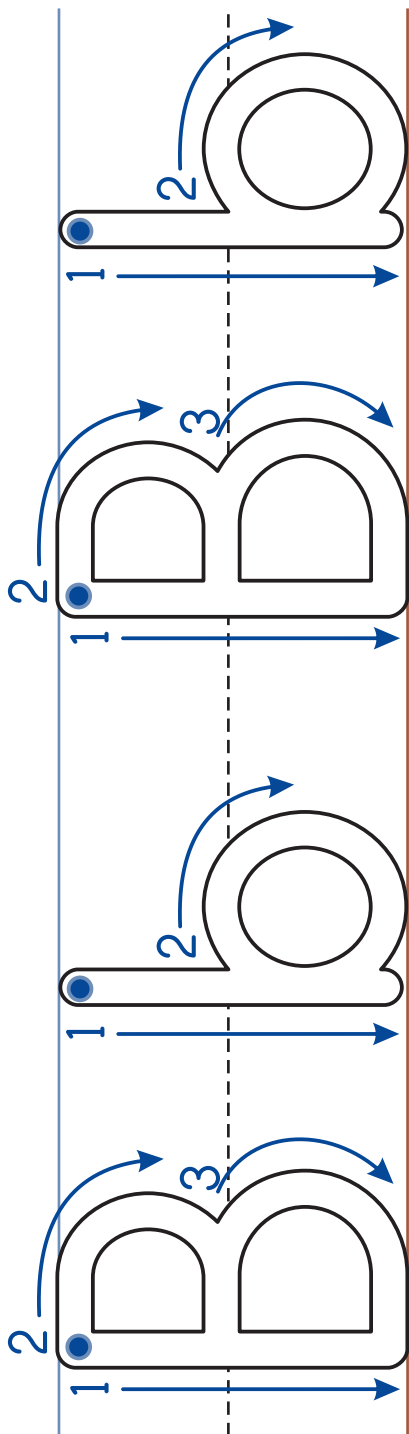

Lavinia Pop © 2013

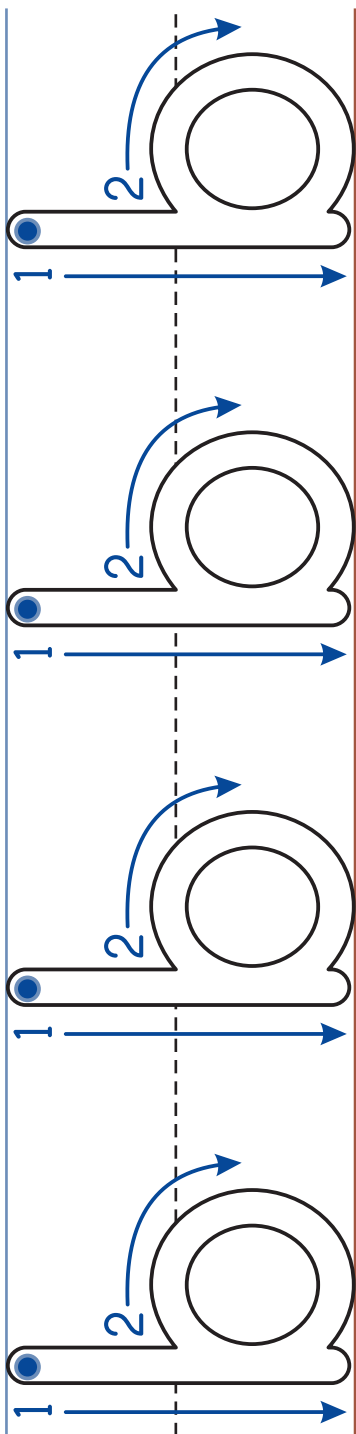

Lavinia Pop © 2013

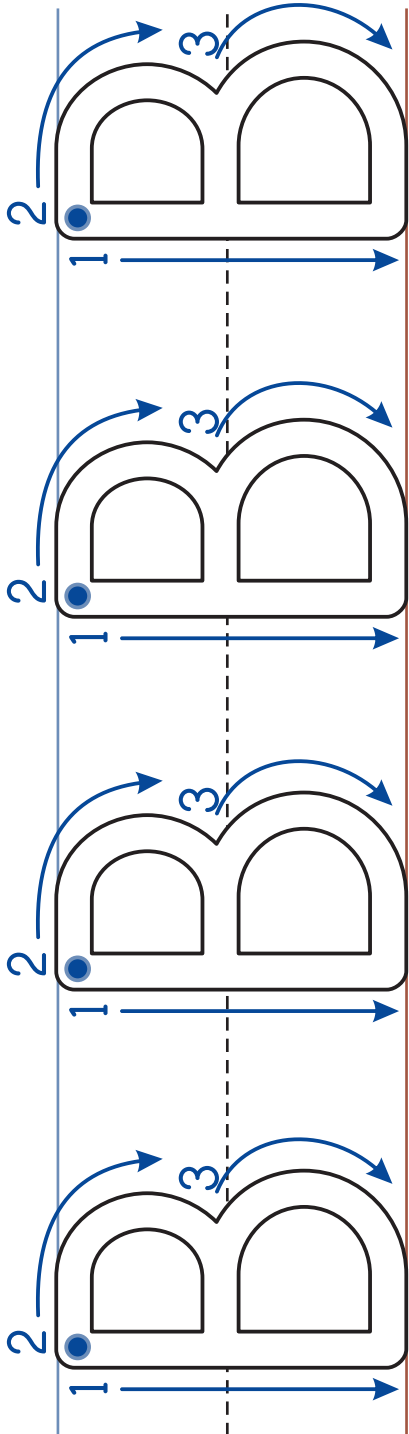

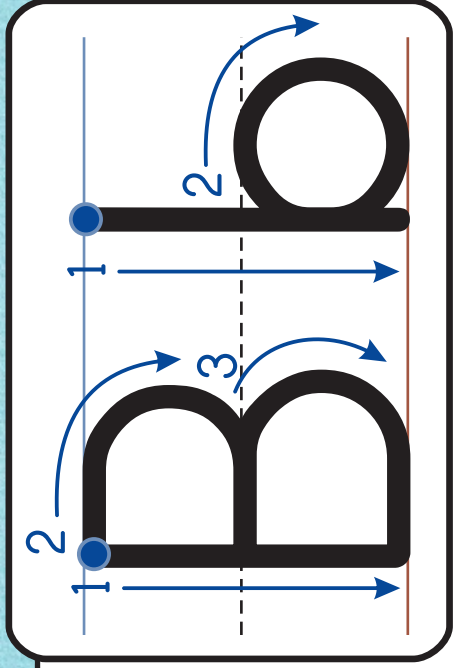

B B B B B

b b b b b

bubbles



bed



box



bus



bug



bat





ball



boots

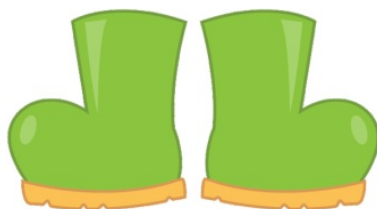

barn



bee



bear



balloons



butterfly



banana



boat

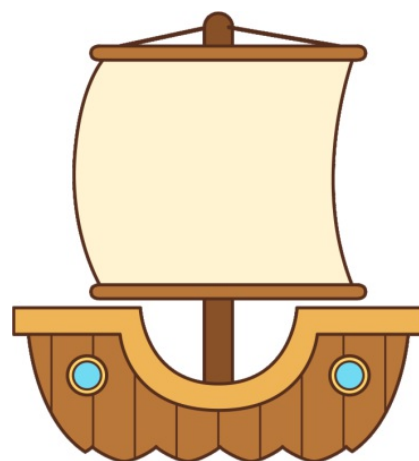

book



belt



bell



bus

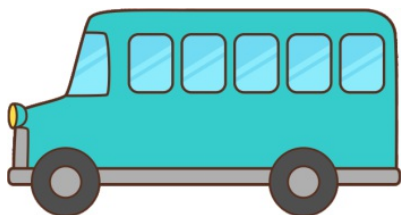

bin



bed



basket



bag



bird



rainbow



umbrella



robot

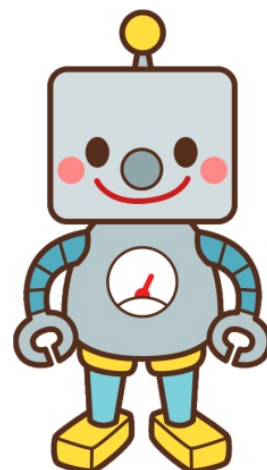

table



cabin



crab



cob



web



cab



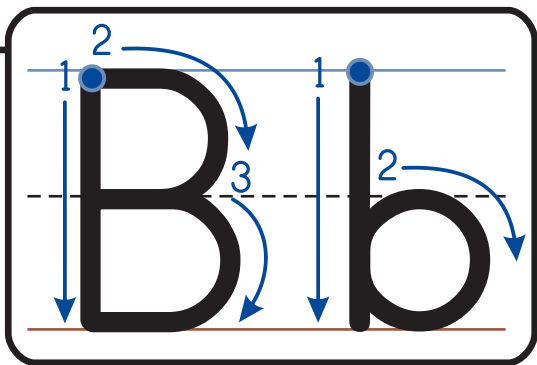

Name \_\_\_\_\_

## Write the Room

These are the Bb words I found in my classroom:

\_\_\_\_\_

\_\_\_\_\_

\_\_\_\_\_

\_\_\_\_\_

\_\_\_\_\_

\_\_\_\_\_

\_\_\_\_\_

\_\_\_\_\_

\_\_\_\_\_

\_\_\_\_\_

\_\_\_\_\_

\_\_\_\_\_

\_\_\_\_\_

\_\_\_\_\_

\_\_\_\_\_

\_\_\_\_\_

\_\_\_\_\_

\_\_\_\_\_

\_\_\_\_\_

\_\_\_\_\_

\_\_\_\_\_

\_\_\_\_\_

\_\_\_\_\_

\_\_\_\_\_

\_\_\_\_\_

\_\_\_\_\_

\_\_\_\_\_

\_\_\_\_\_

\_\_\_\_\_

\_\_\_\_\_

\_\_\_\_\_

\_\_\_\_\_

\_\_\_\_\_

\_\_\_\_\_

\_\_\_\_\_

\_\_\_\_\_

\_\_\_\_\_

\_\_\_\_\_

\_\_\_\_\_

\_\_\_\_\_

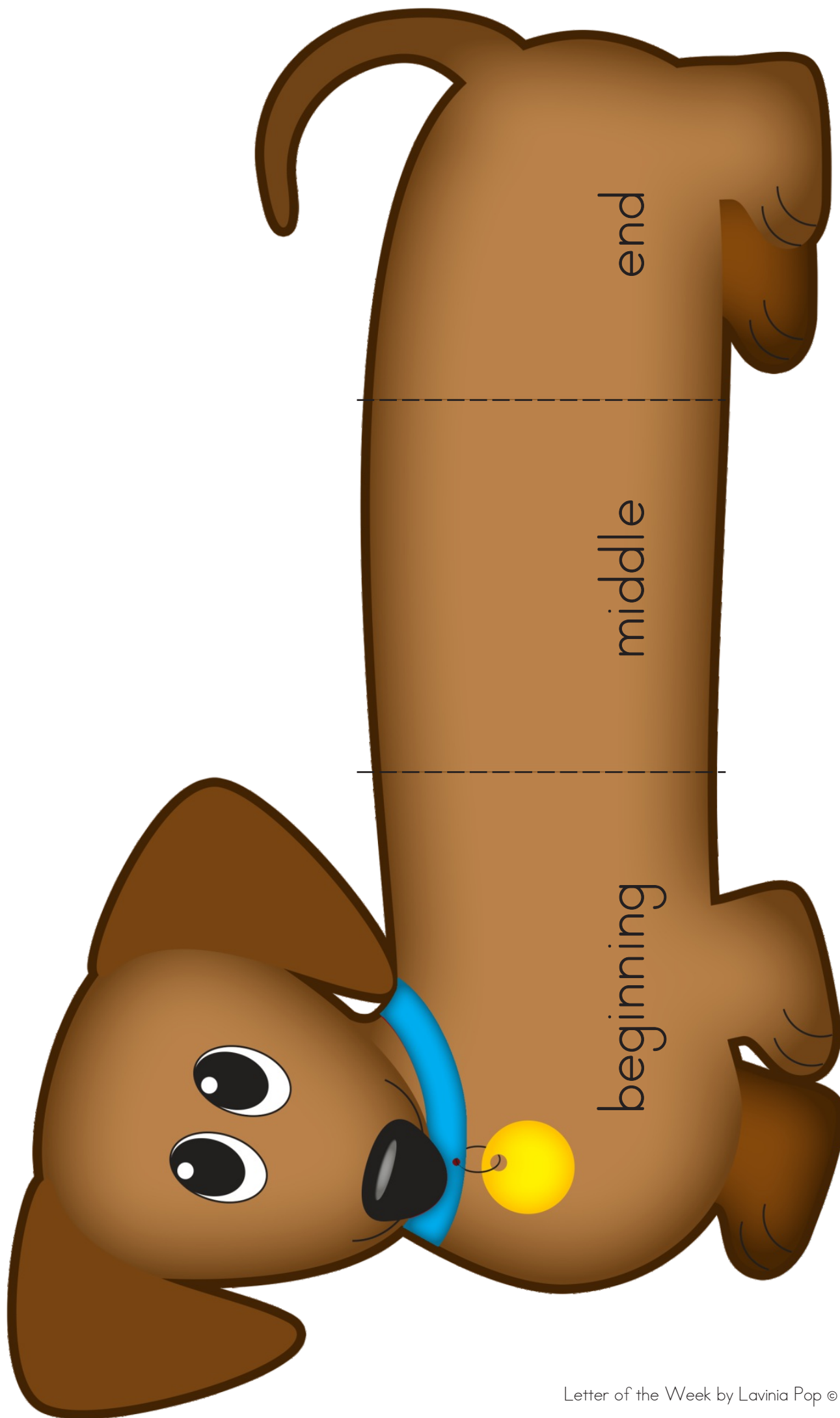



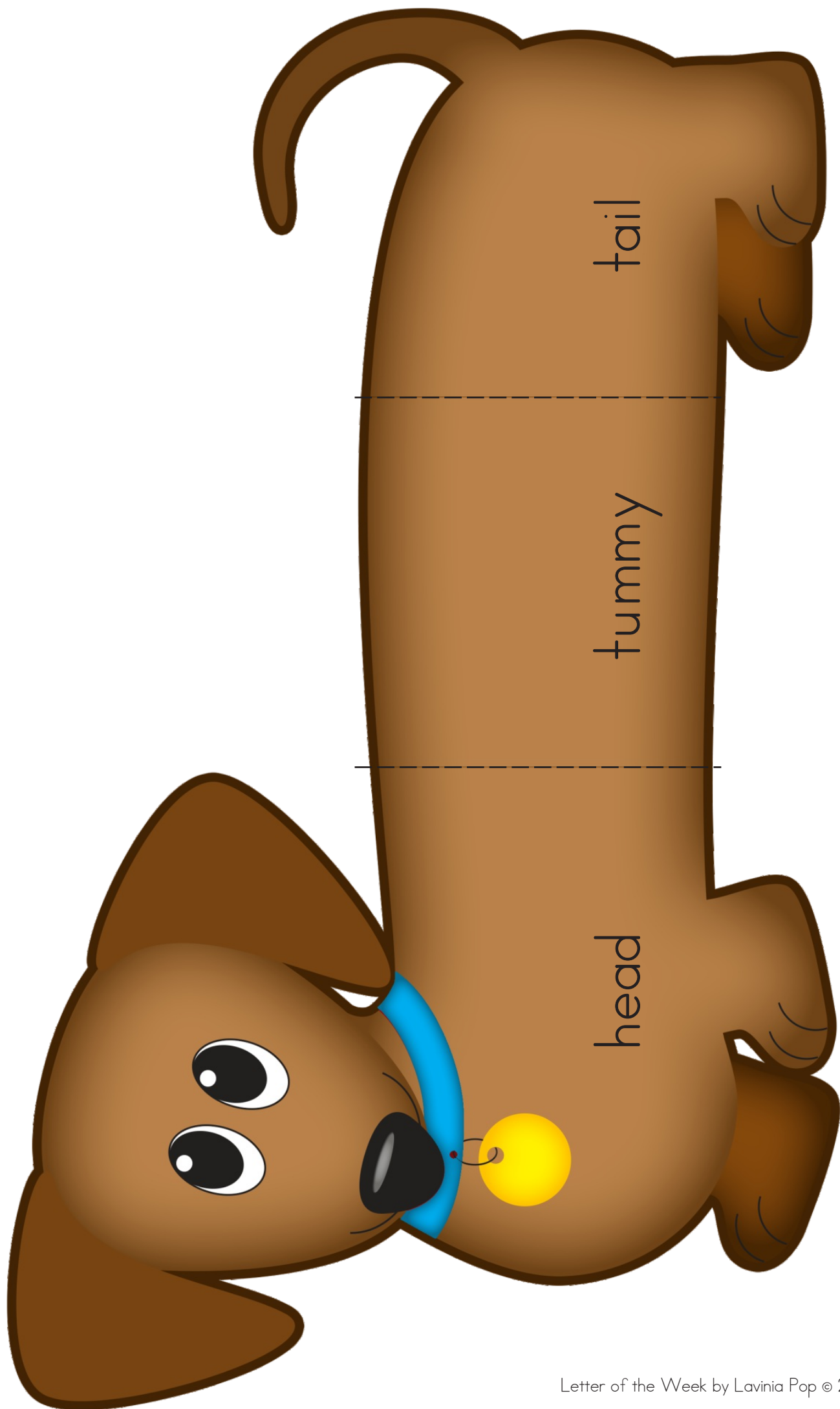

b



b

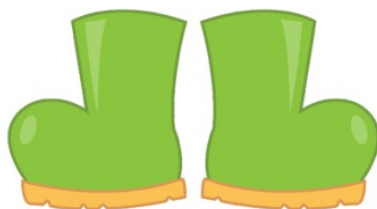

b



b



b



b



b



b



b

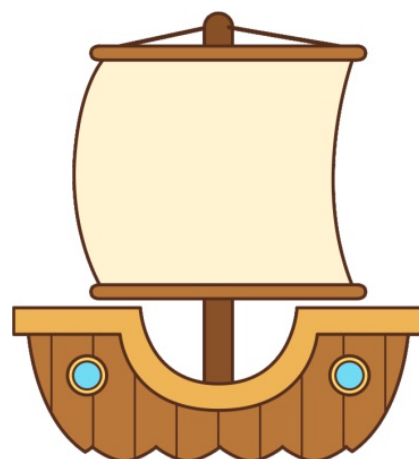

b



b



b

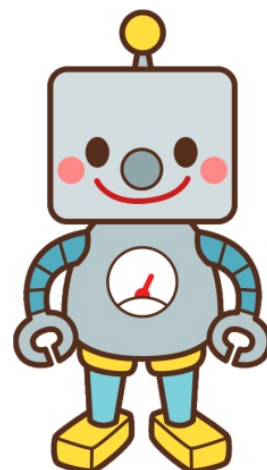

b



b



b



b



b



b



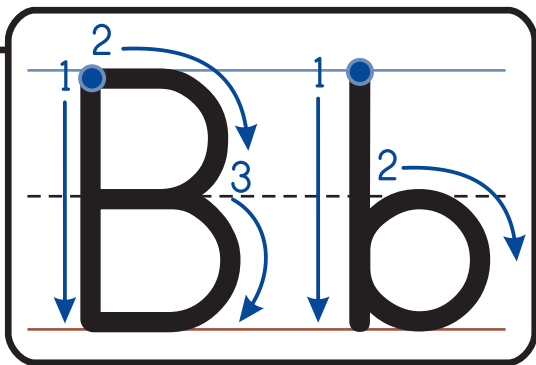



Name \_\_\_\_\_

### Doggie, Where's the Sound?

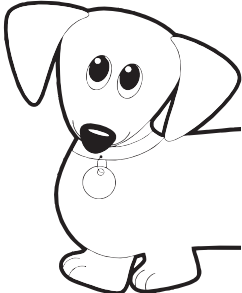
Cut and paste the Bb pictures in the correct Doggie Sound column.



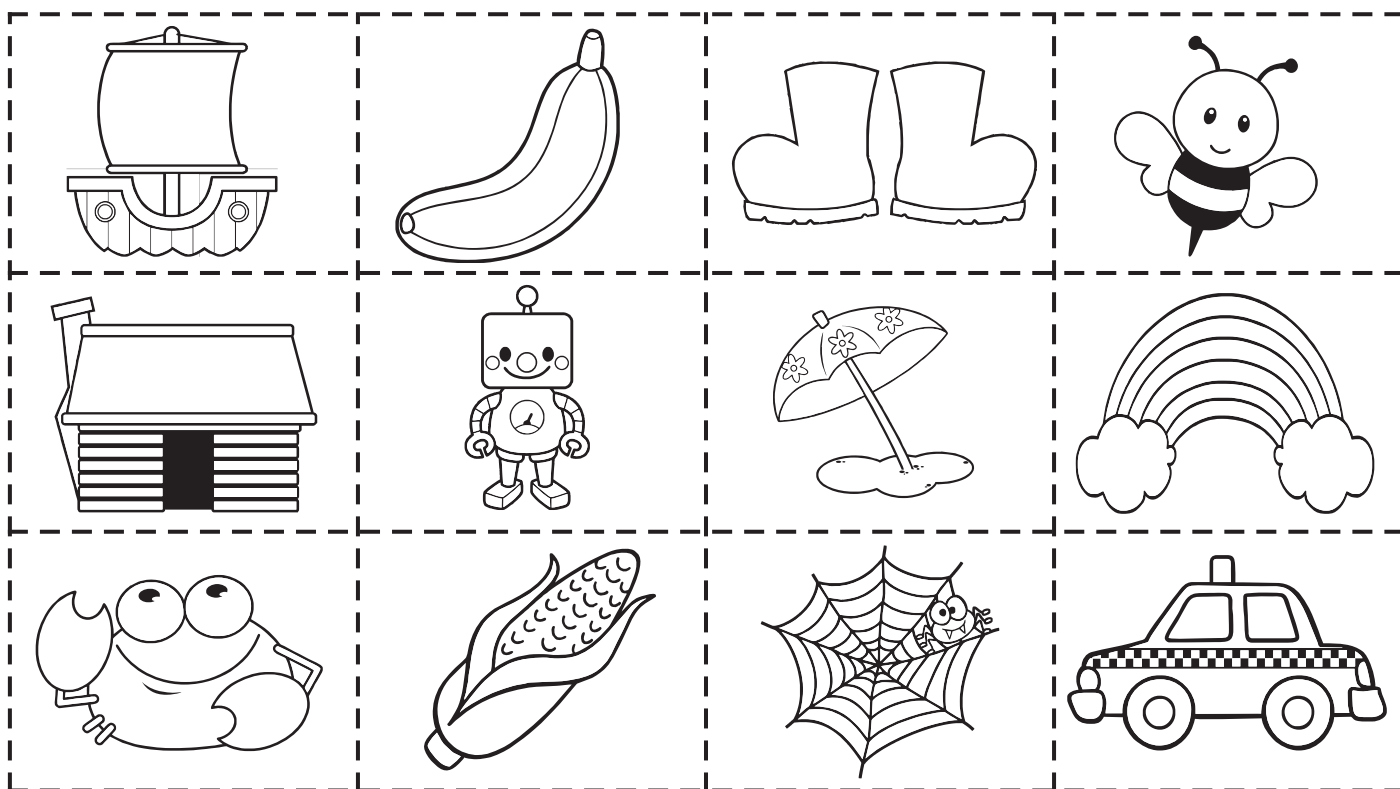
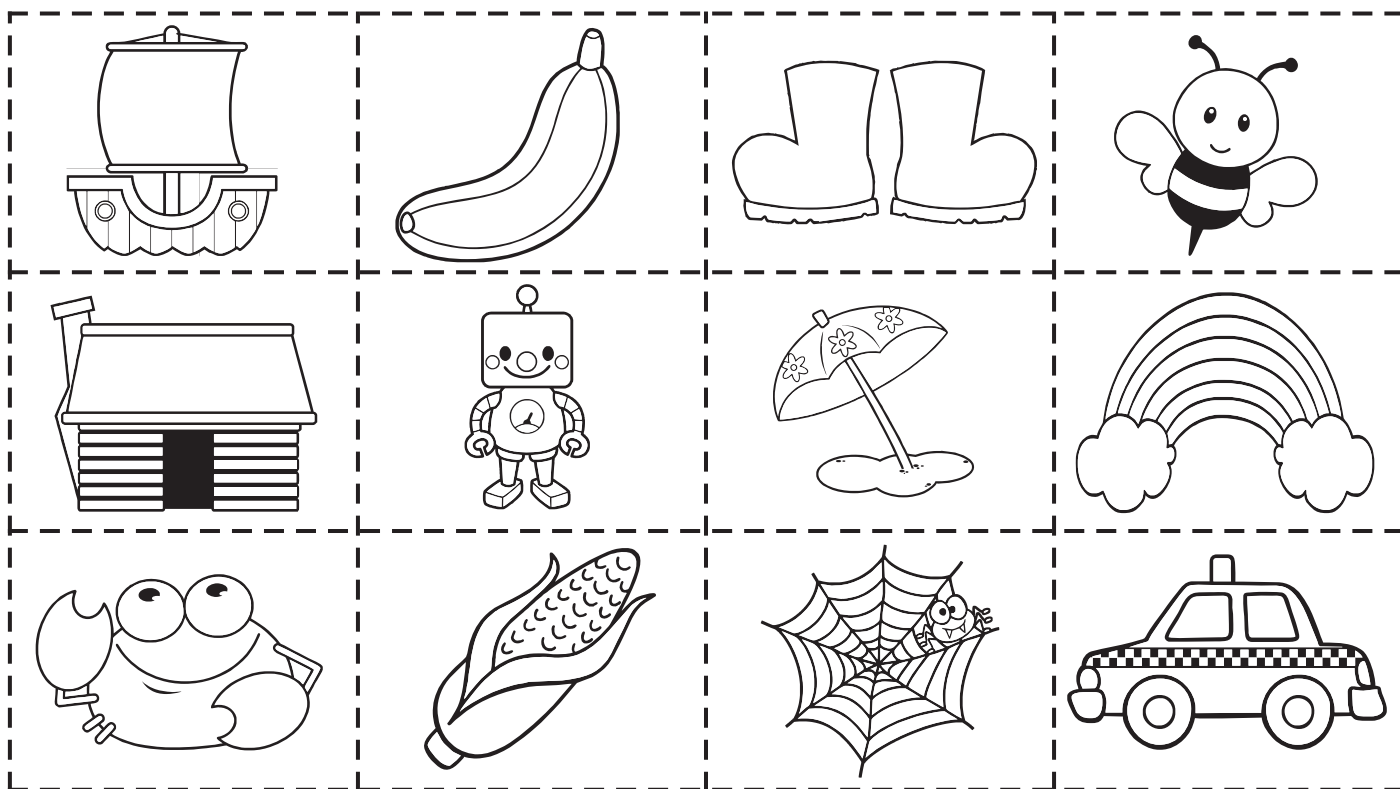

 <p>Bob</p>	<p>brings</p>	<p>a</p>	
 <p>bear.</p>	 <p>boat.</p>	 <p>bike.</p>	 <p>balloon.</p>
 <p>basket.</p>	 <p>book.</p>	 <p>bird.</p>	 <p>bat.</p>

# Build-a-Sentence

Name: \_\_\_\_\_

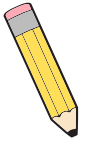

Trace and complete the sentence using Bb words.

Bob brings a

1. \_\_\_\_\_

2. \_\_\_\_\_

3. \_\_\_\_\_

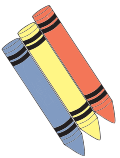

Draw a picture of a Bb word.

I

see

d

By Lavinia Pop © 2013

Glue/Staple

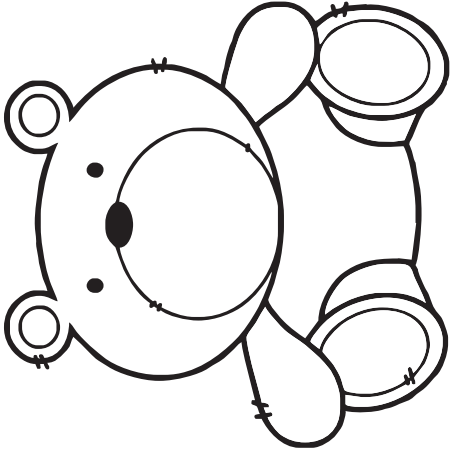

bear.

Glue/Staple

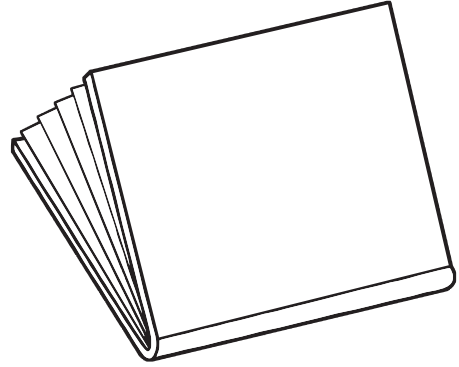

book.

Glue/Staple

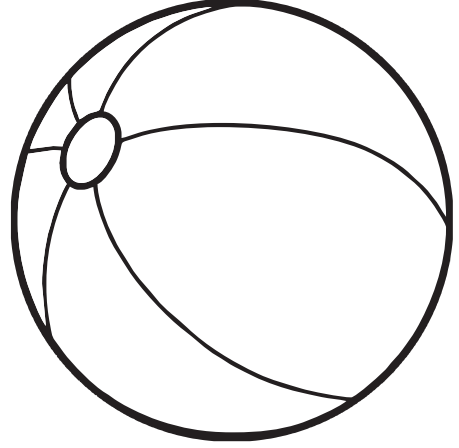

ball.

Glue/Staple

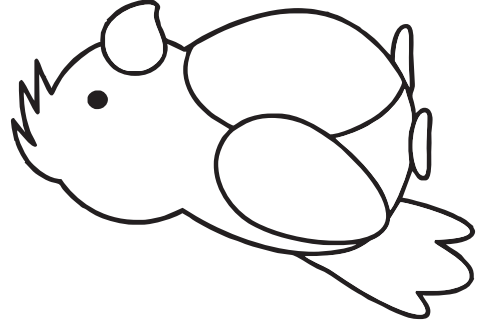

bird.

Glue/Staple

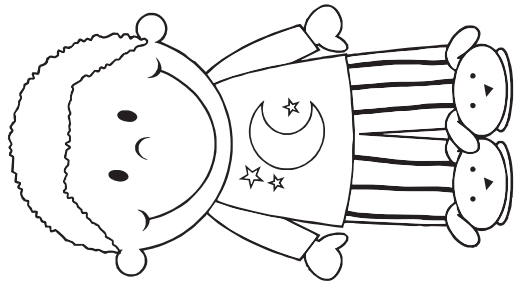

boy.



I

see

d

By Lavinia Pop © 2013

Glue/Staple



bear.

Glue/Staple



book.

Glue/Staple



ball.

Glue/Staple



boy.

Glue/Staple

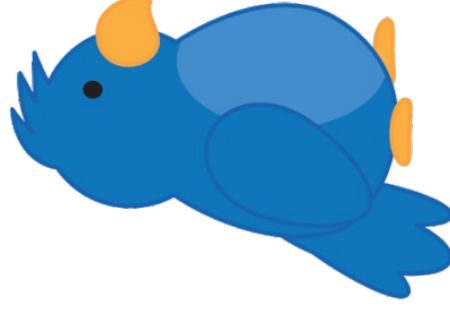

bird.

# Letter of the Week

## Flip Book

Name \_\_\_\_\_

Write the flip book sentence using one Bb word.

\_\_\_\_\_

-----

\_\_\_\_\_

-----

\_\_\_\_\_

The Bb word I chose is...

\_\_\_\_\_

-----

\_\_\_\_\_

Another Bb word is...

\_\_\_\_\_

-----

\_\_\_\_\_

A picture of my flip book sentence

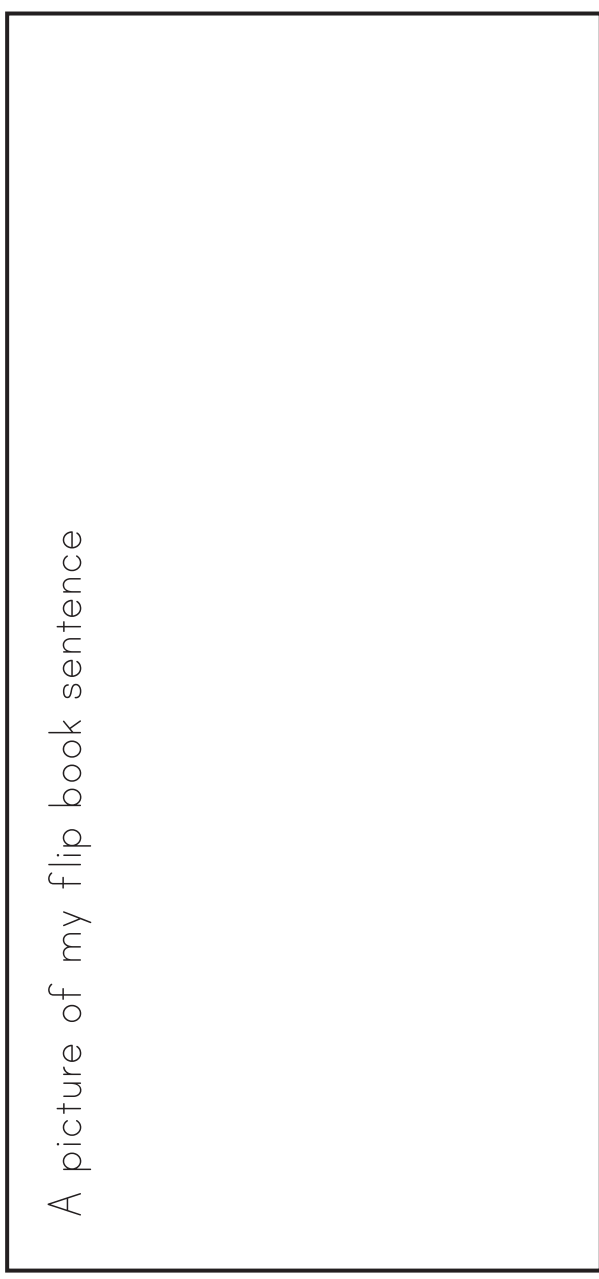

# Letter of the Week

## Flip Book

Name \_\_\_\_\_

These are my flip book words and pictures:

\_\_\_\_\_

-----

\_\_\_\_\_

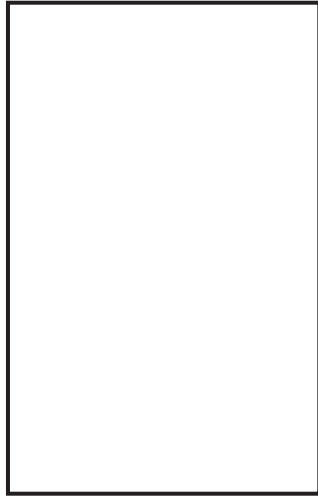
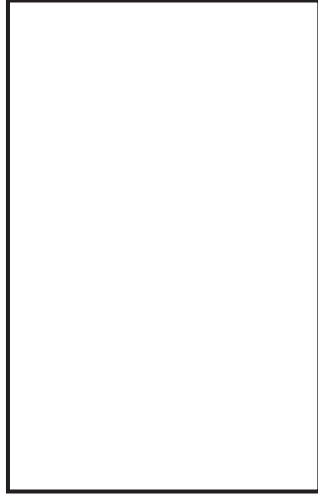
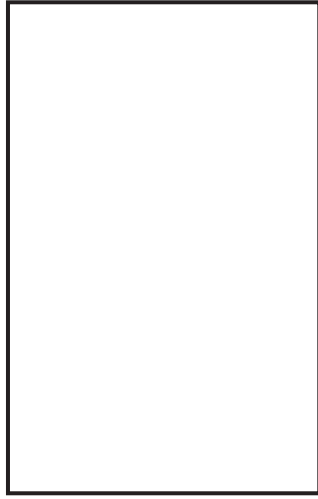

\_\_\_\_\_

-----

\_\_\_\_\_

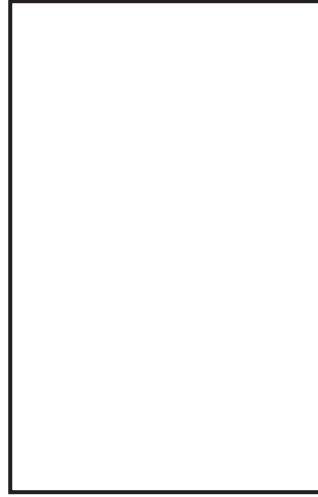
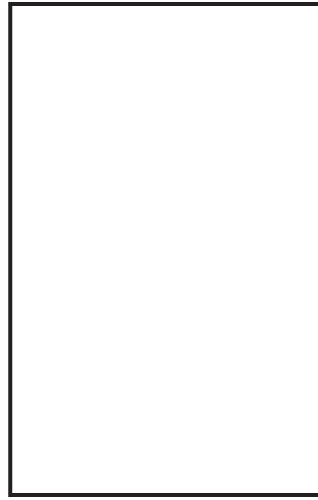

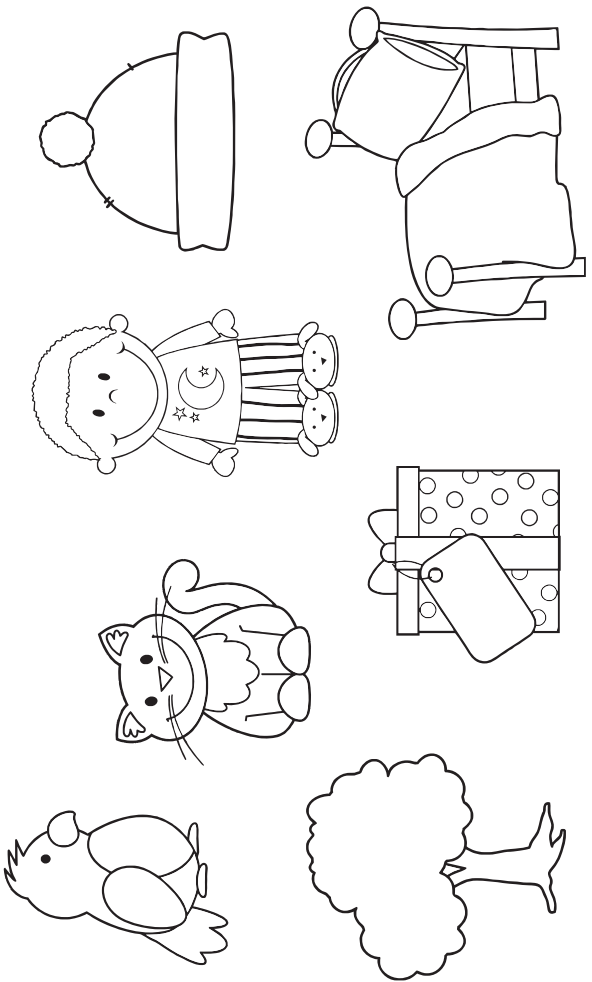

Circle the pictures that begin with Bb.

Color B and b.

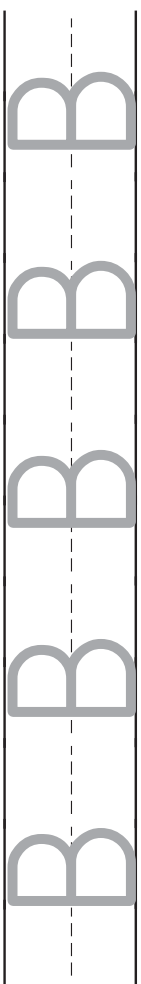
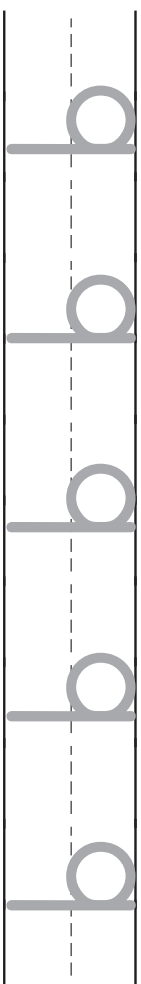
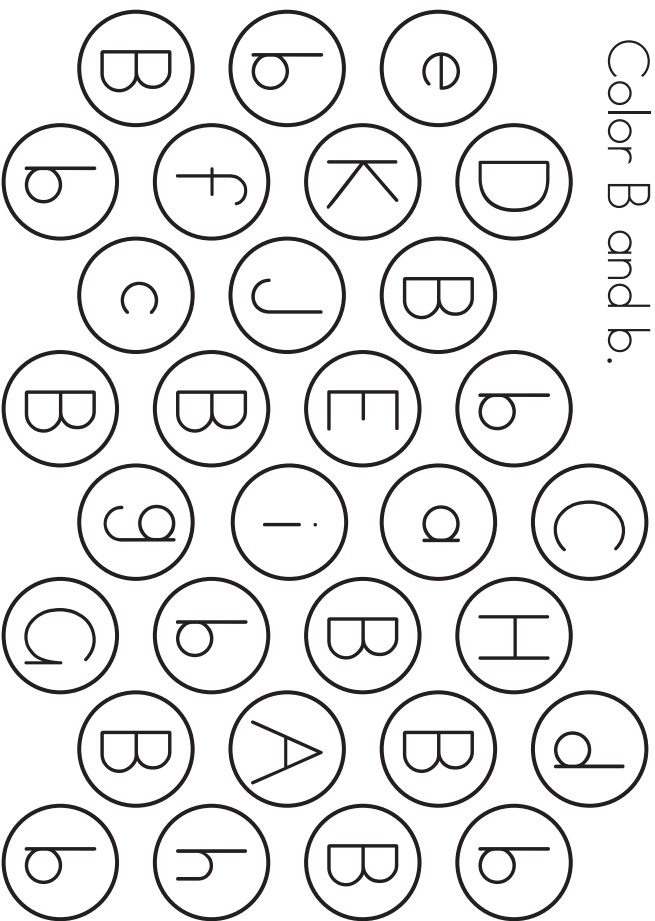

Trace B and b.

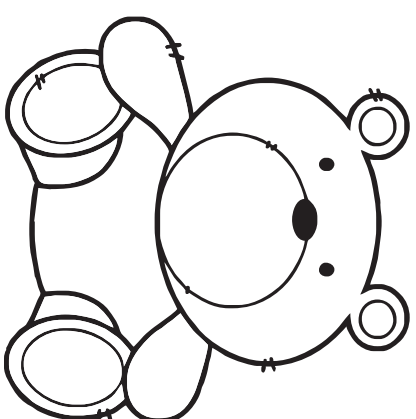

My

Bb

Book

\_\_\_\_\_

I see a big...

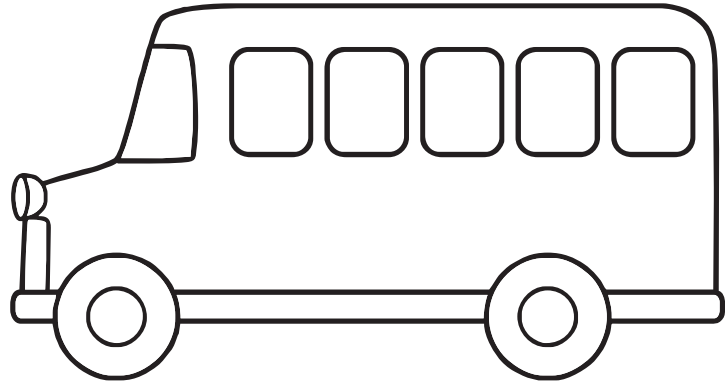

Bb

Name: \_\_\_\_\_

I see a big...

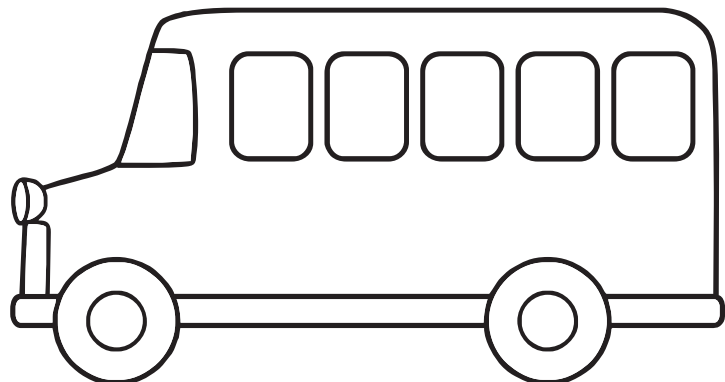

Bb

Name: \_\_\_\_\_





I see a big bag.



I see a big bag.

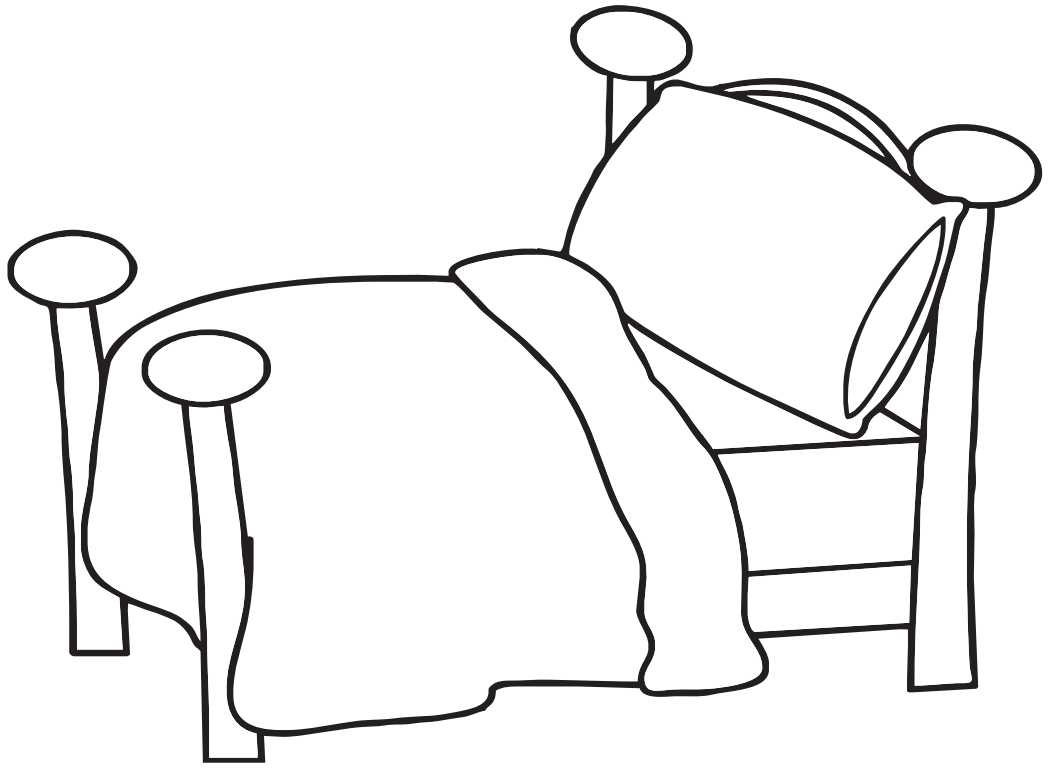

I see a big bed.

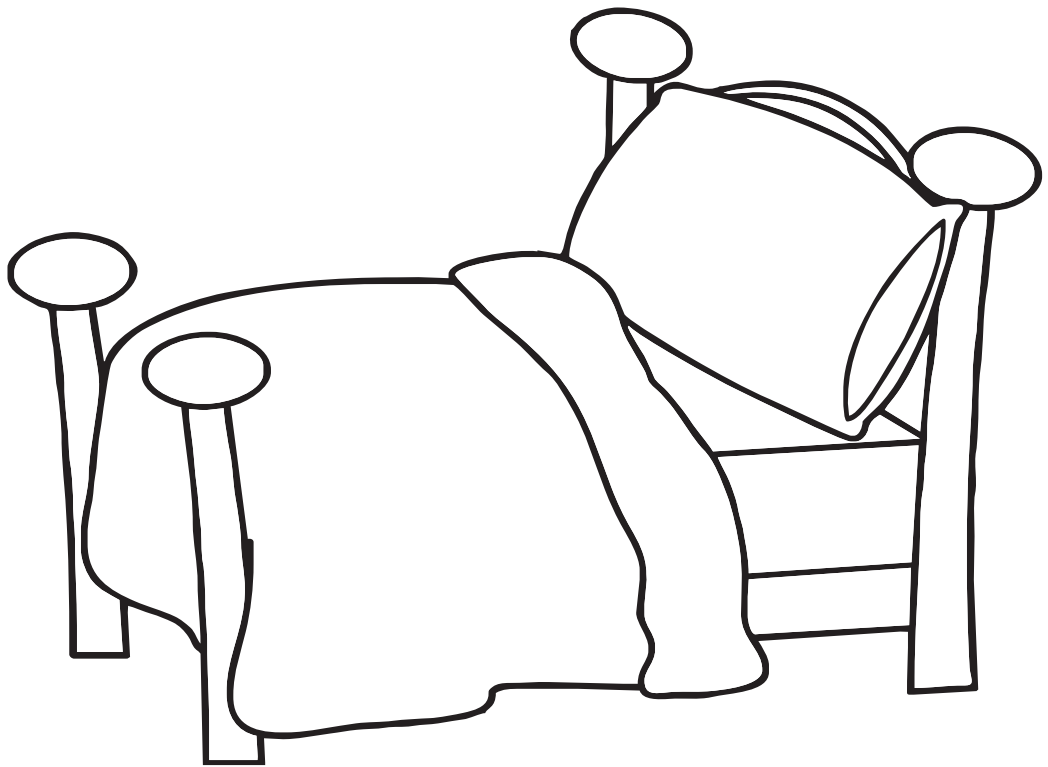

I see a big bed.

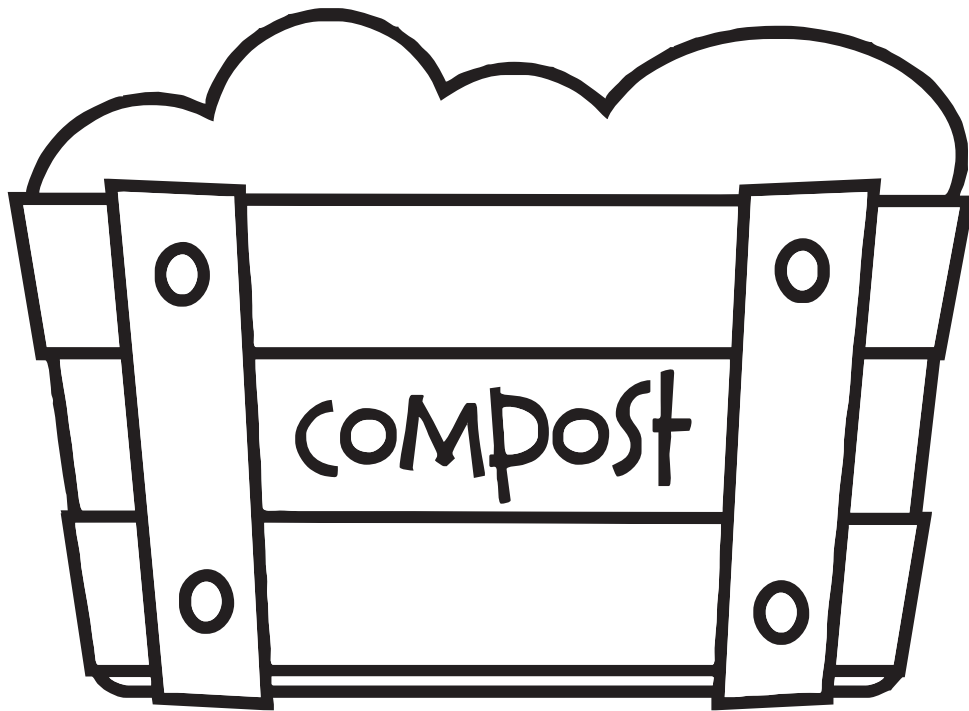

I see a big bin.

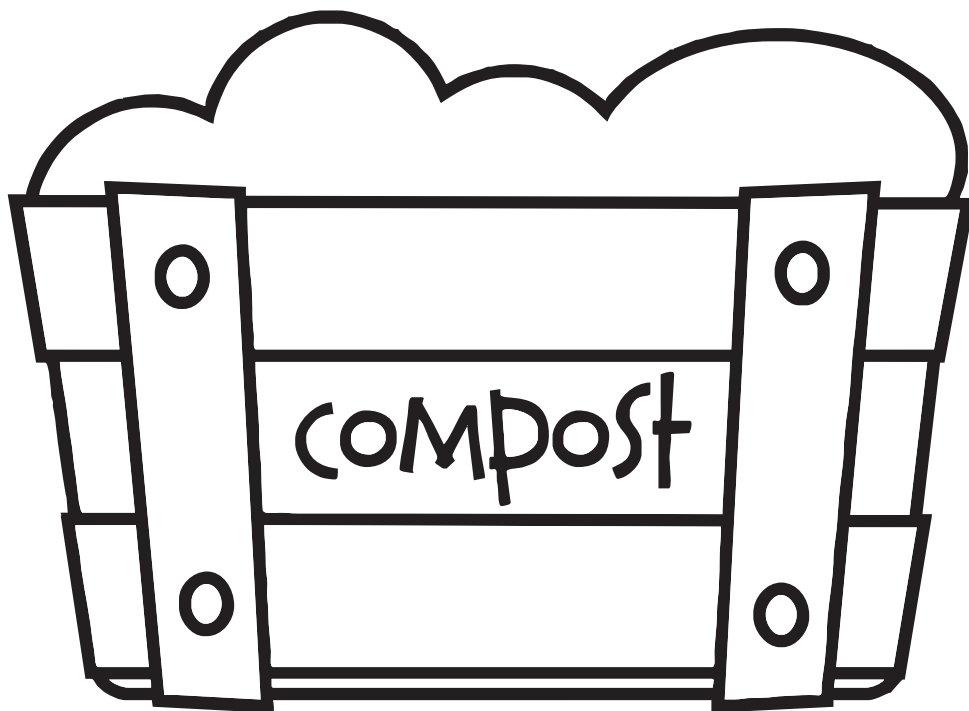

I see a big bin.

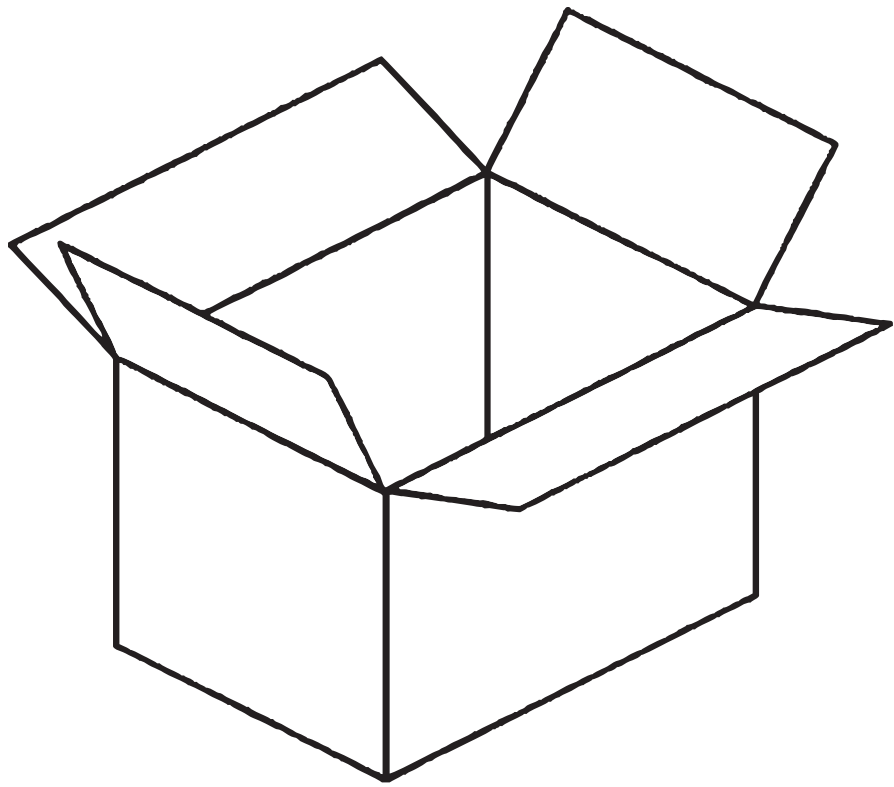

I see a big box.

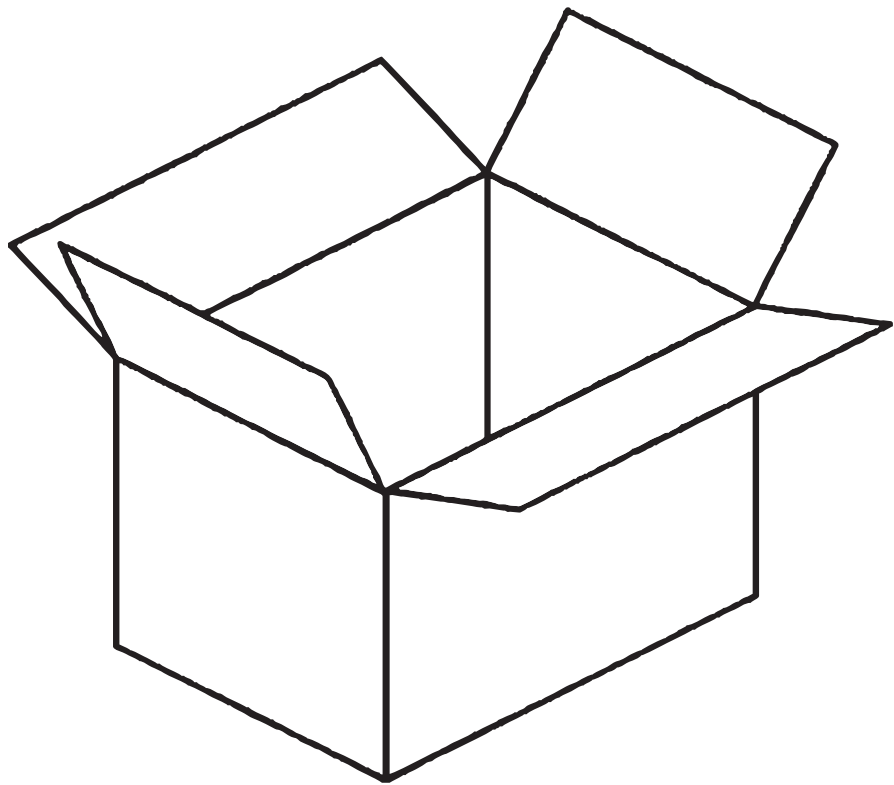

I see a big box.

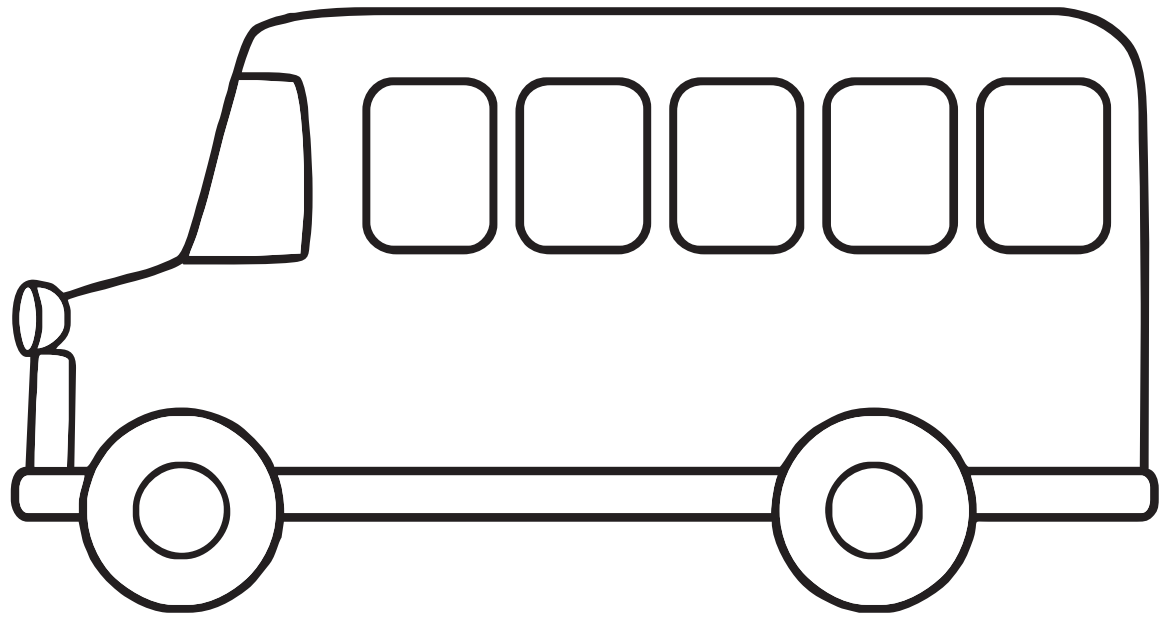

I see a big bus.

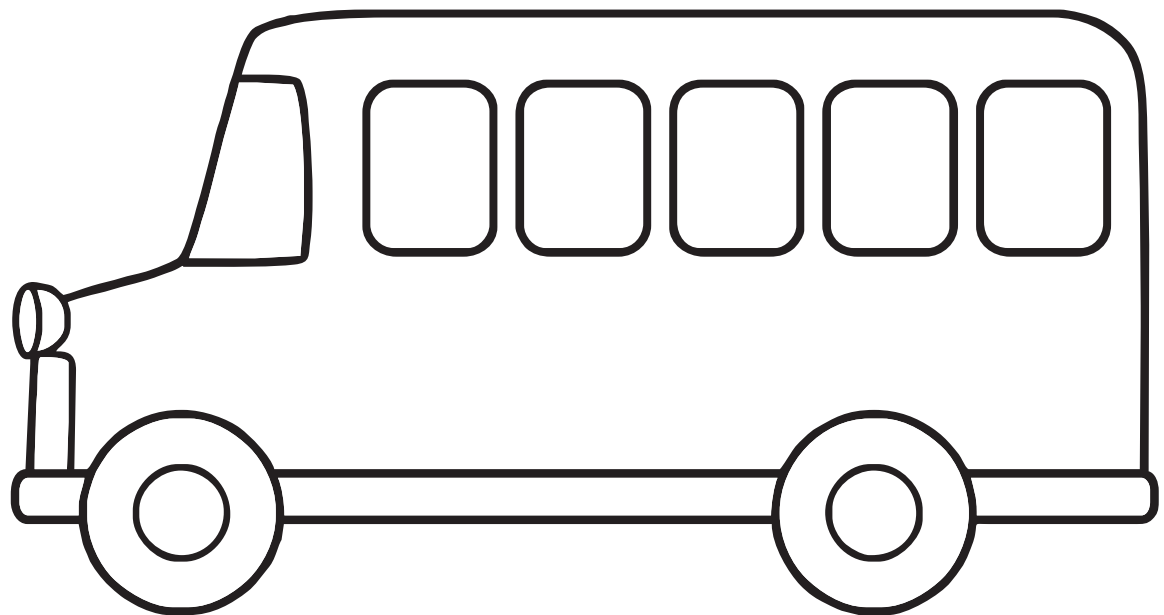

I see a big bus.

I see a big...

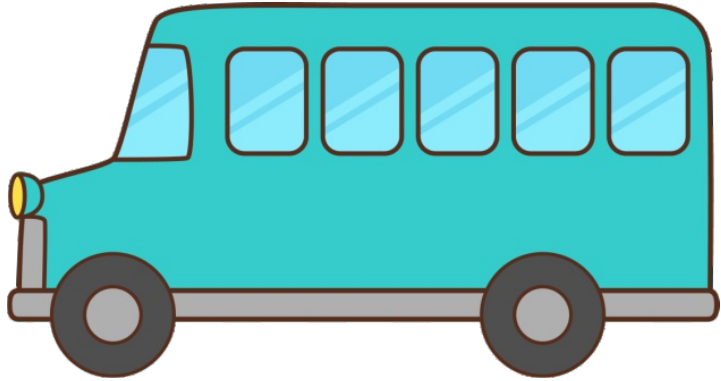

Bb

Name: \_\_\_\_\_

I see a big...

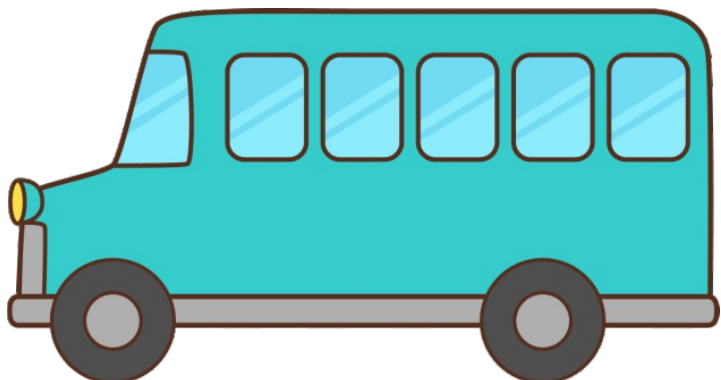

Bb

Name: \_\_\_\_\_





I see a big bag.



I see a big bag.



I see a big bed.



I see a big bed.



I see a big bin.



I see a big bin.



I see a big box.



I see a big box.

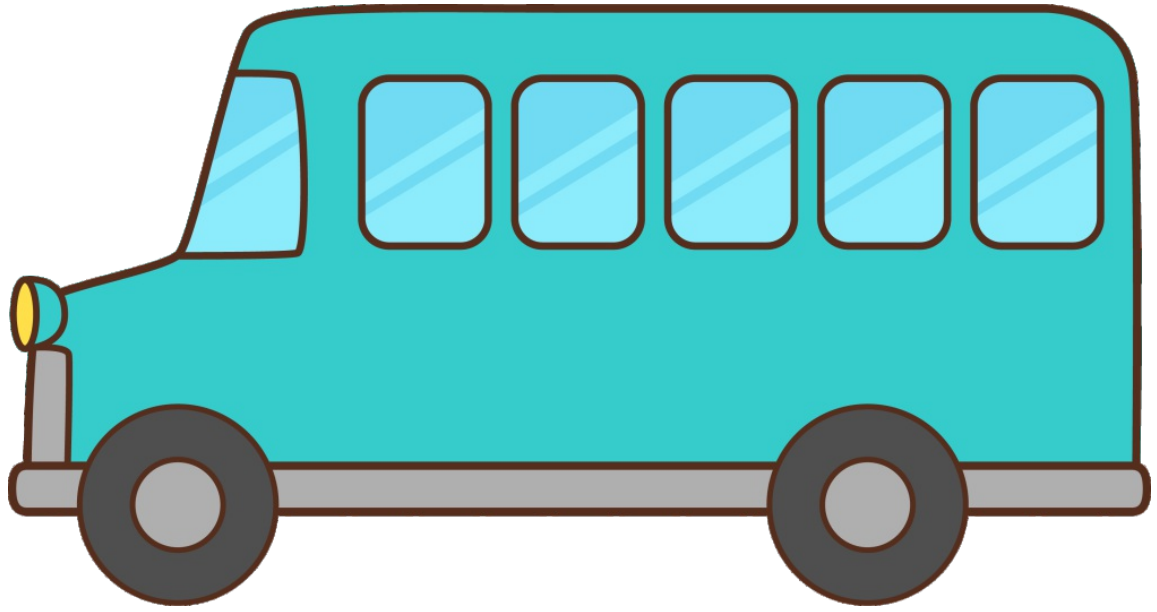

I see a big bus.

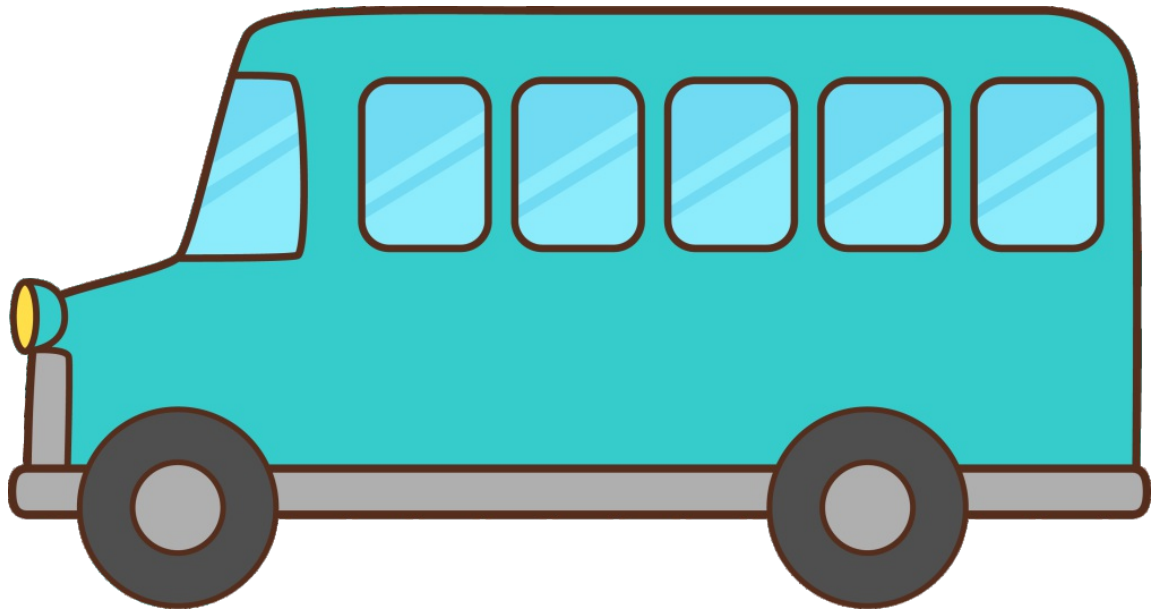

I see a big bus.

Missing Letter Cut & Paste



Name: \_\_\_\_\_

Missing Letter Cut & Paste



Name: \_\_\_\_\_



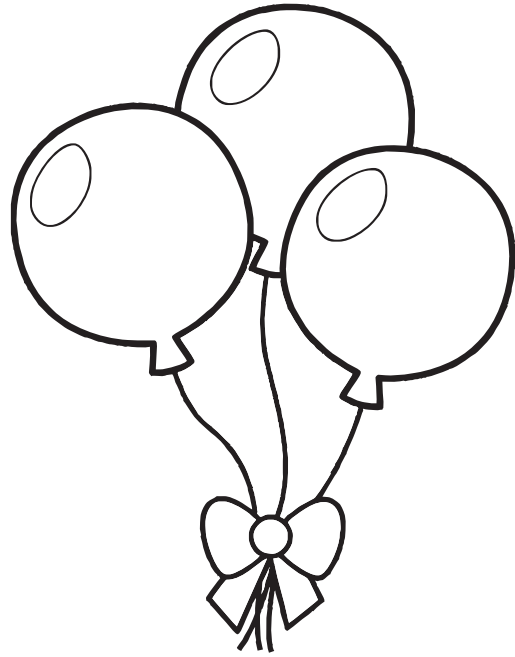
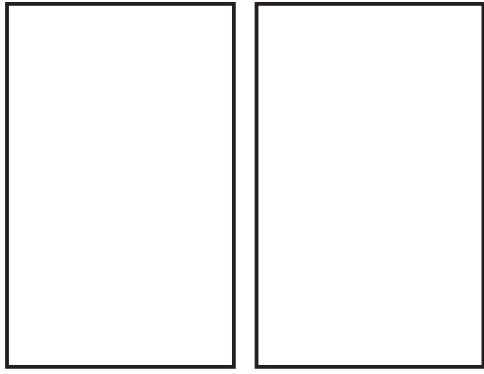

i is for balloons.

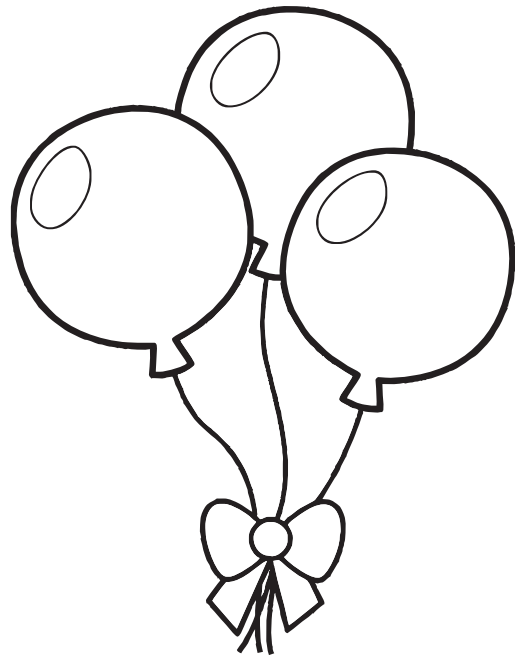
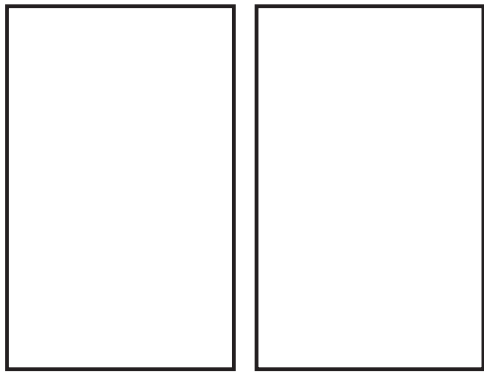

i is for balloons.

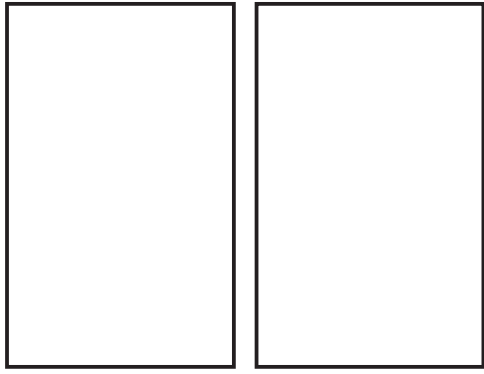

is for bear.

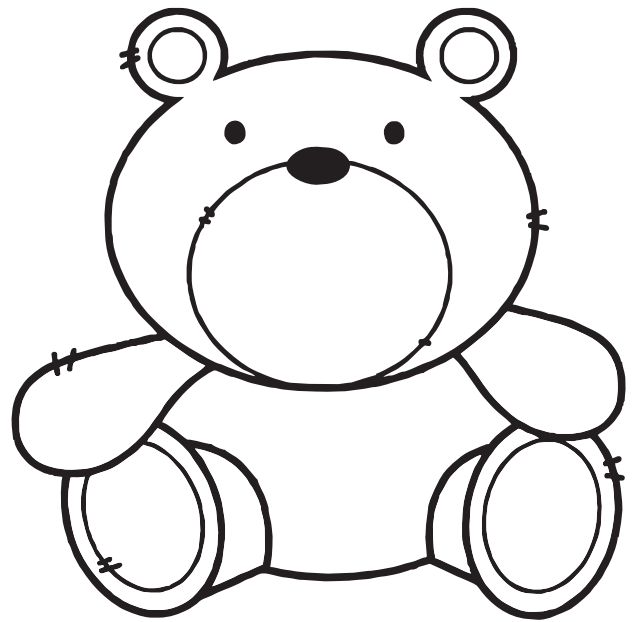
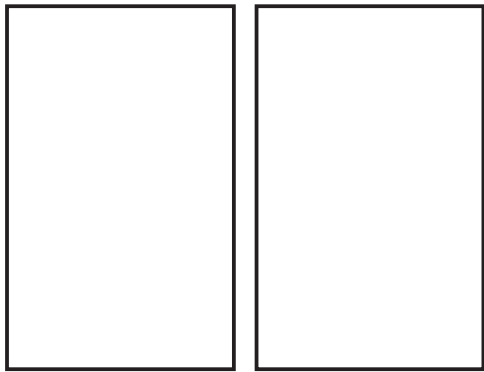

is for bear.

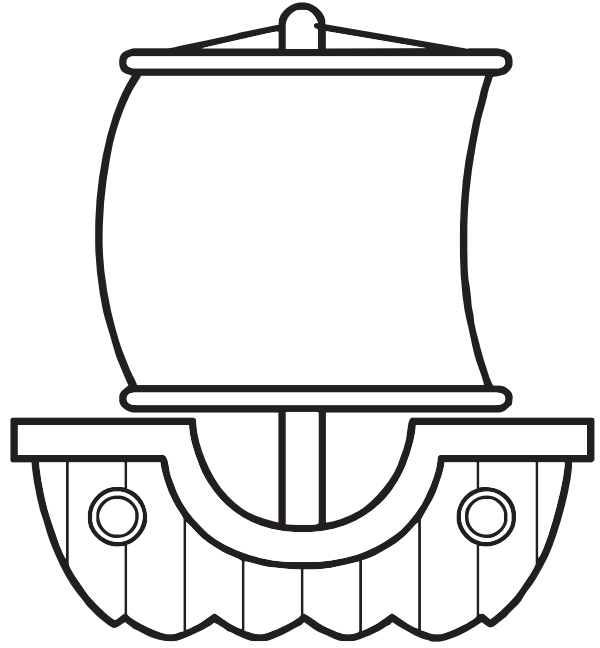
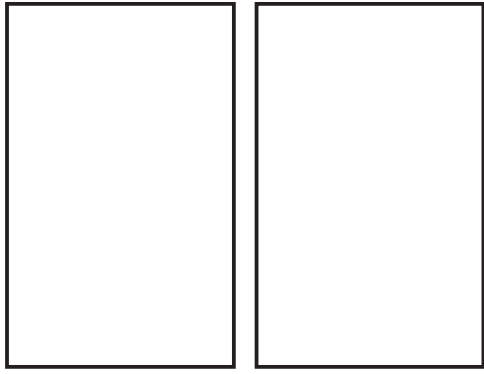

i s for boat.

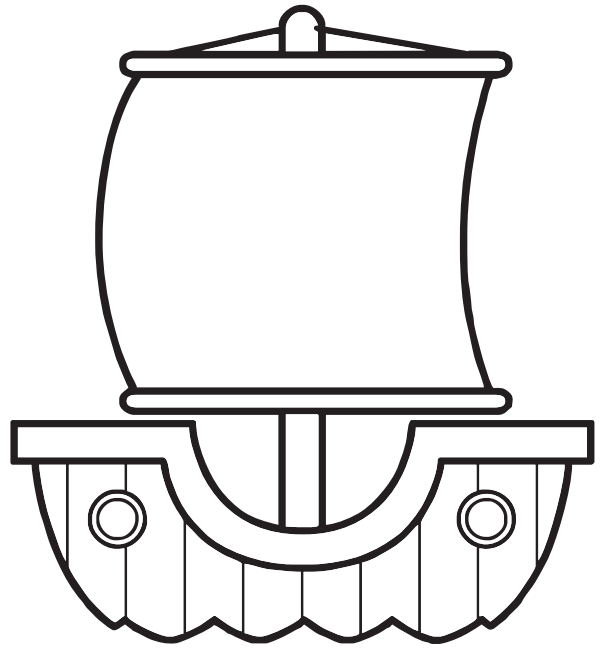
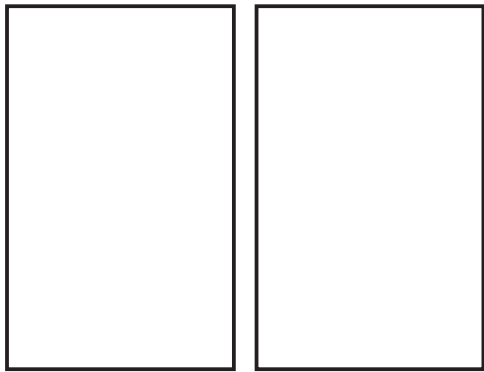

i s for boat.

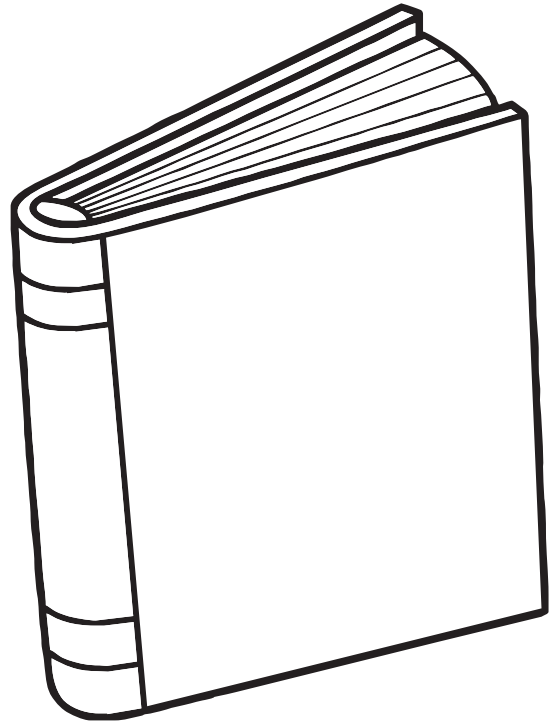
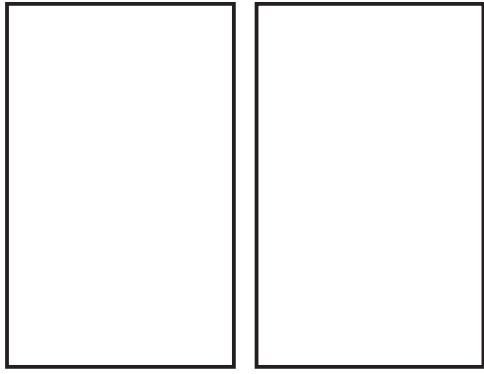

is for book.

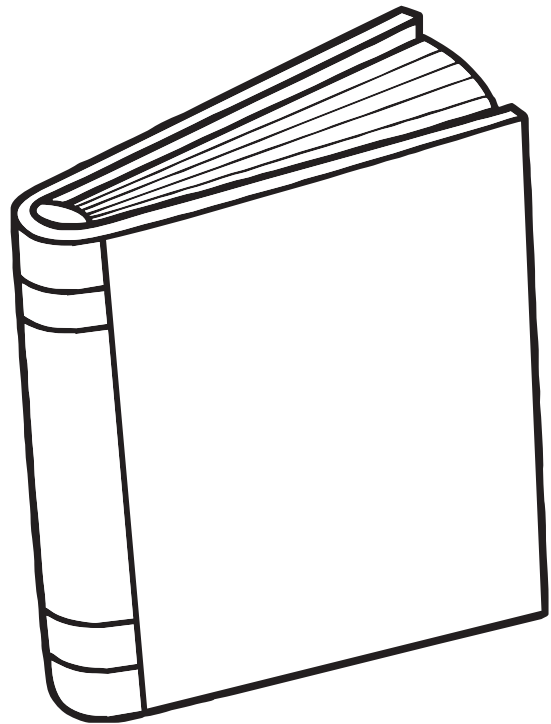
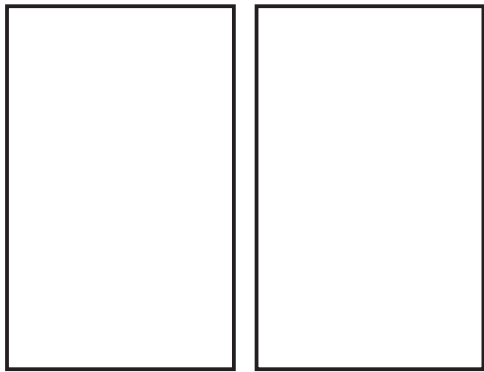

is for book.

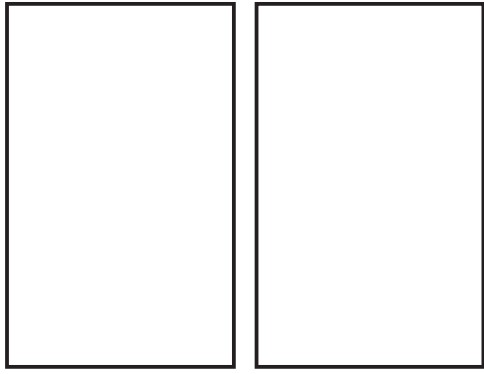

i s for ball.

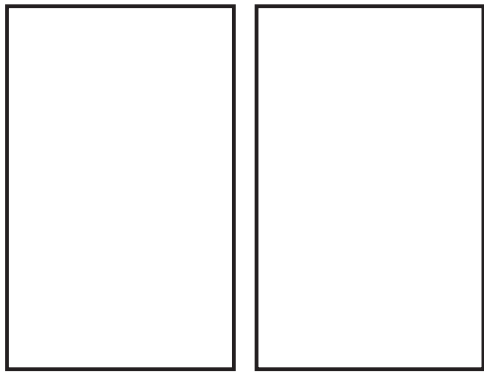

i s for ball.

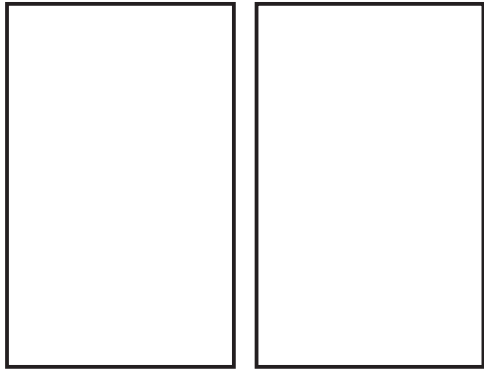

b is for bike.

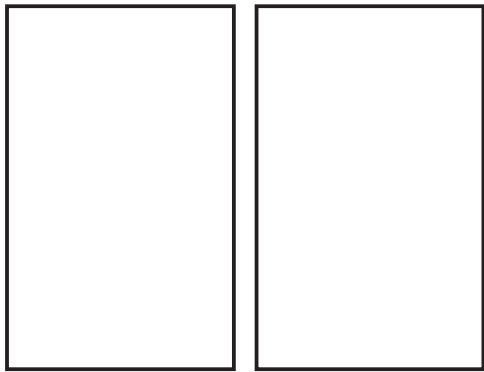

b is for bike.



B

b

B

b

B

b

B

b

B

b

B

b

B

b

B

b

B

b

B

b

B

b

B

b

B

b

B

b

B

b

B

b

B

b

B

b

Picture Scramble Cut & Paste

B b

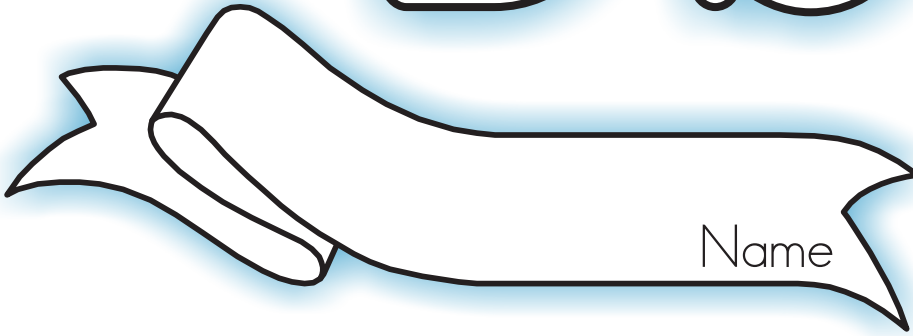

bag  
bed  
bib  
box  
bun  
bus

Picture Scramble Cut & Paste

B b

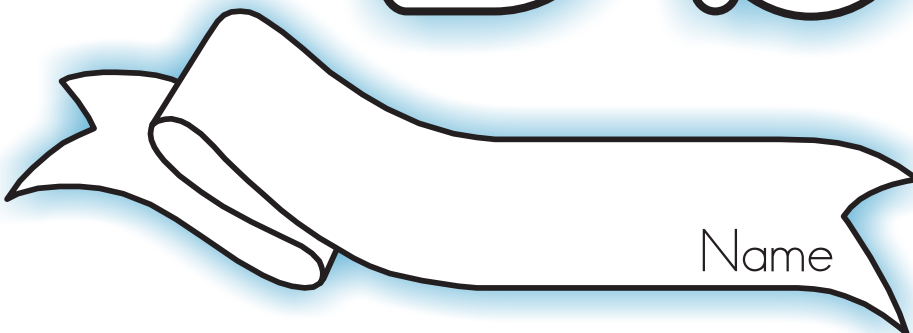

bag  
bed  
bib  
box  
bun  
bus

bag

bag

--	--	--

bag

bag

--	--	--

bed

bed

Handwriting practice lines consisting of two sets of three horizontal lines (top, dashed middle, bottom) for tracing.

--	--	--

bed

bed

Handwriting practice lines consisting of two sets of three horizontal lines (top, dashed middle, bottom) for tracing.

--	--	--

bib

bib

Blank handwriting lines for practice.

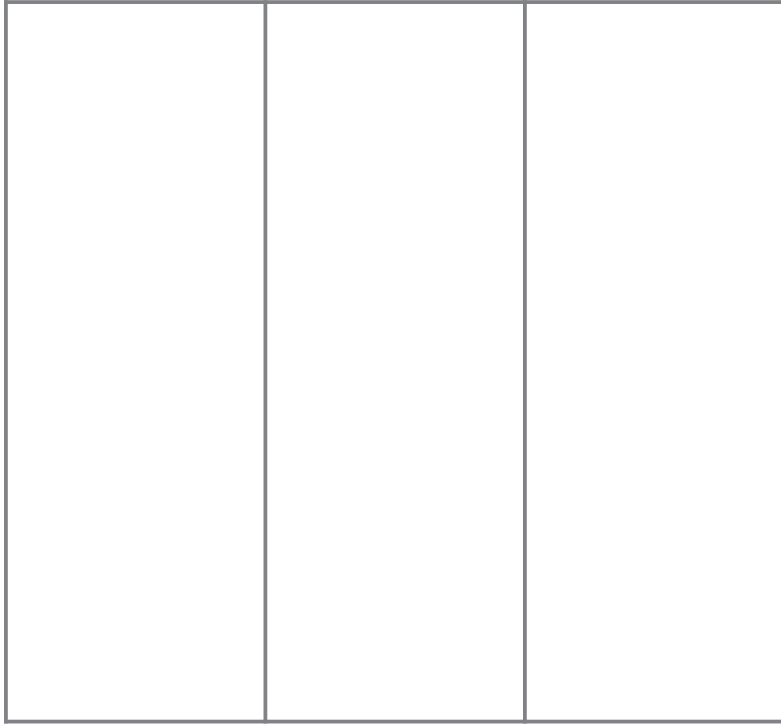

bib

bib

Blank handwriting lines for practice.

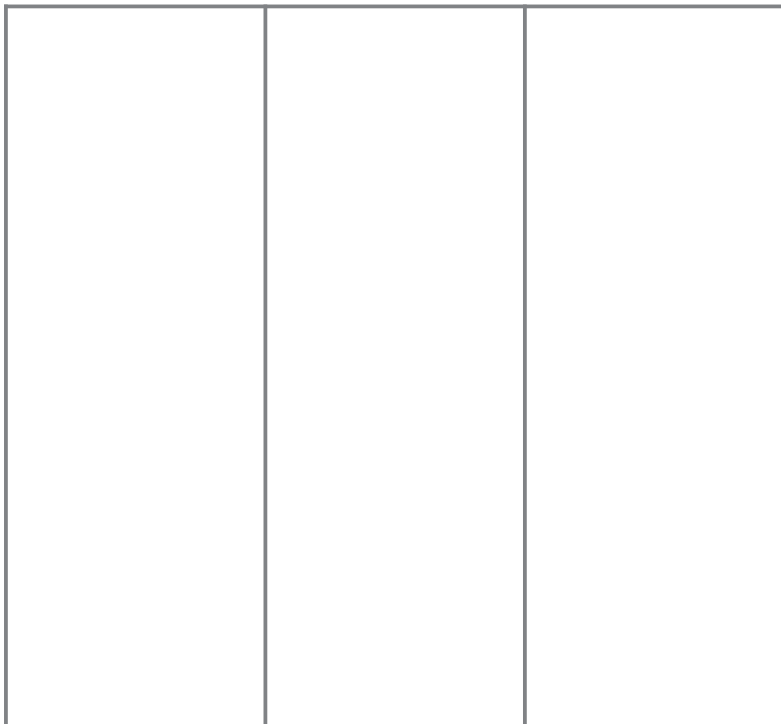

box

box

Blank handwriting lines for practice.

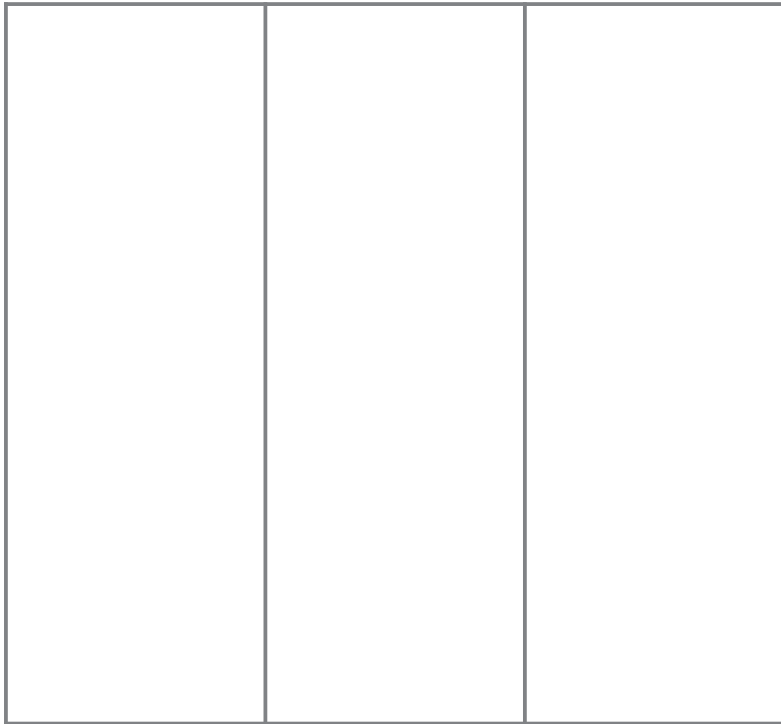

box

box

Blank handwriting lines for practice.

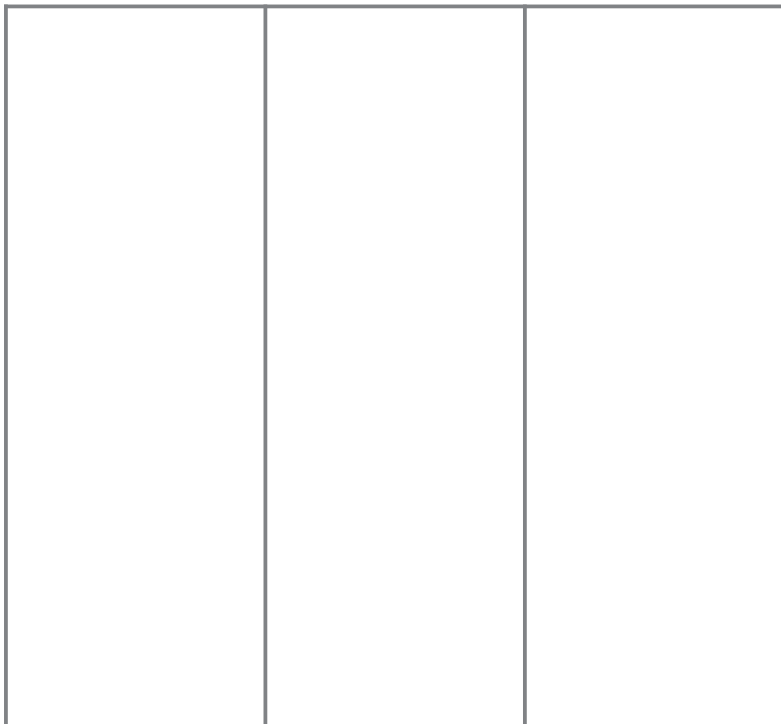



bun

bun

--	--	--

bun

bun

--	--	--

bus

bus

Handwriting practice lines consisting of two sets of three horizontal lines (top, dashed middle, bottom) for tracing and independent writing.

--	--	--

bus

bus

Handwriting practice lines consisting of two sets of three horizontal lines (top, dashed middle, bottom) for tracing and independent writing.

--	--	--

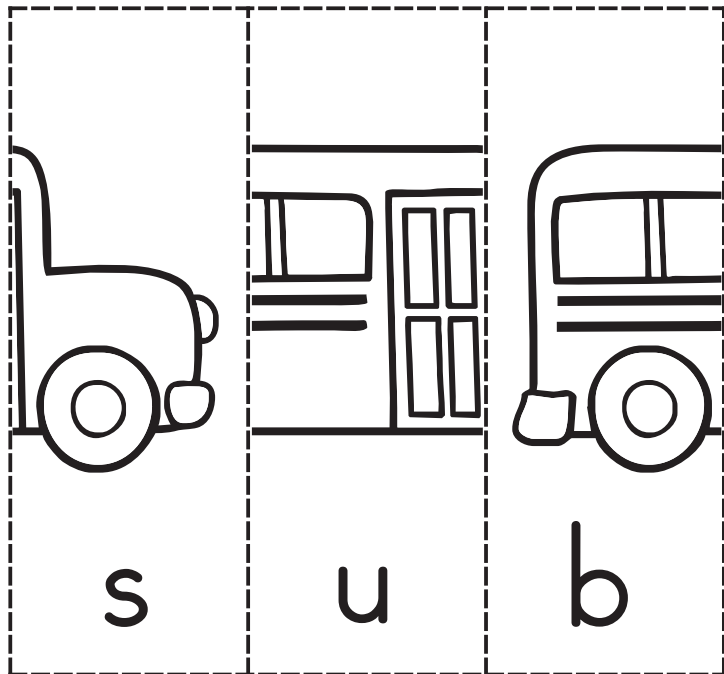
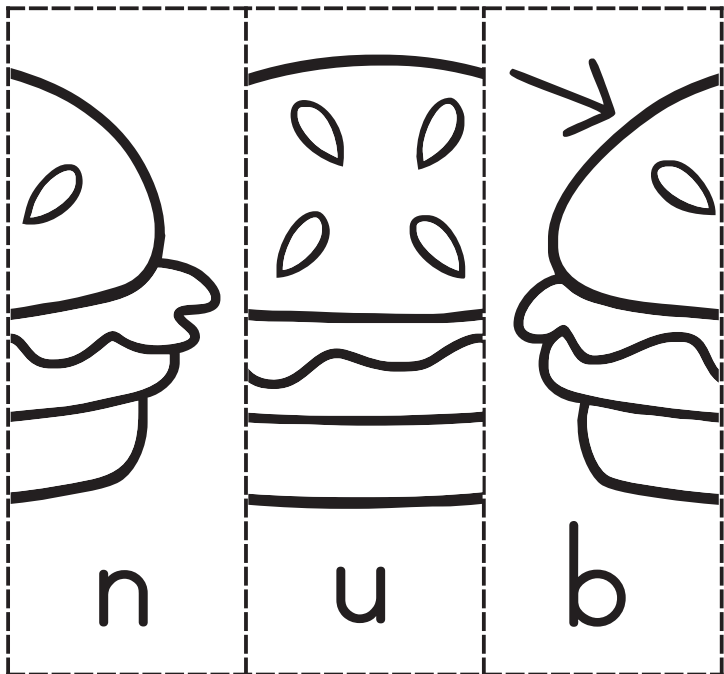
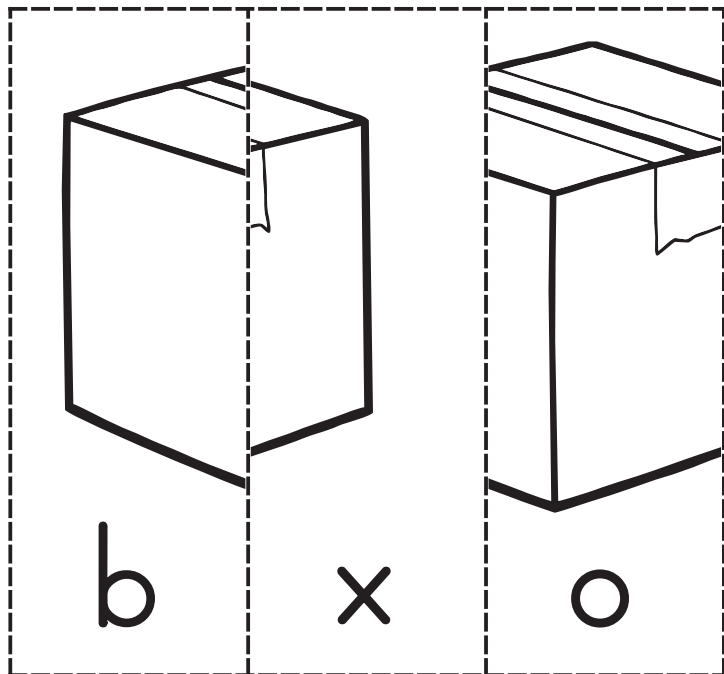
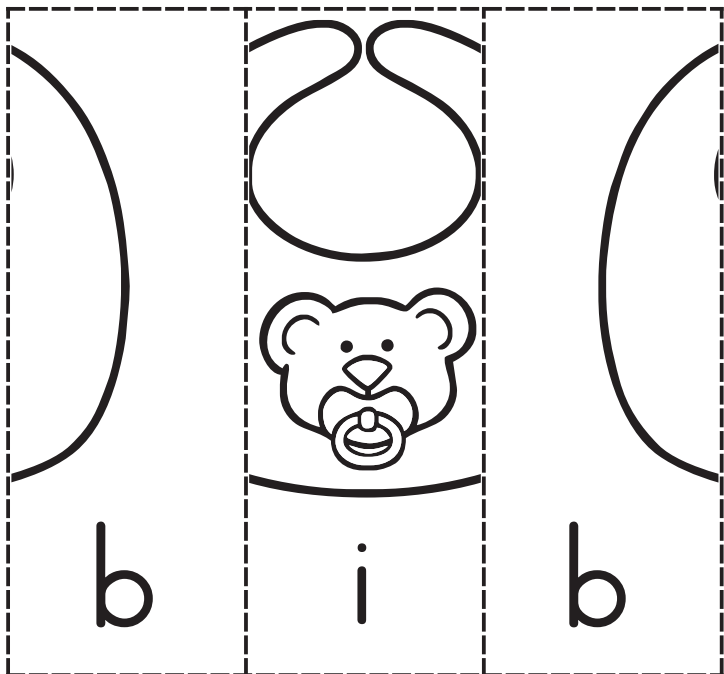
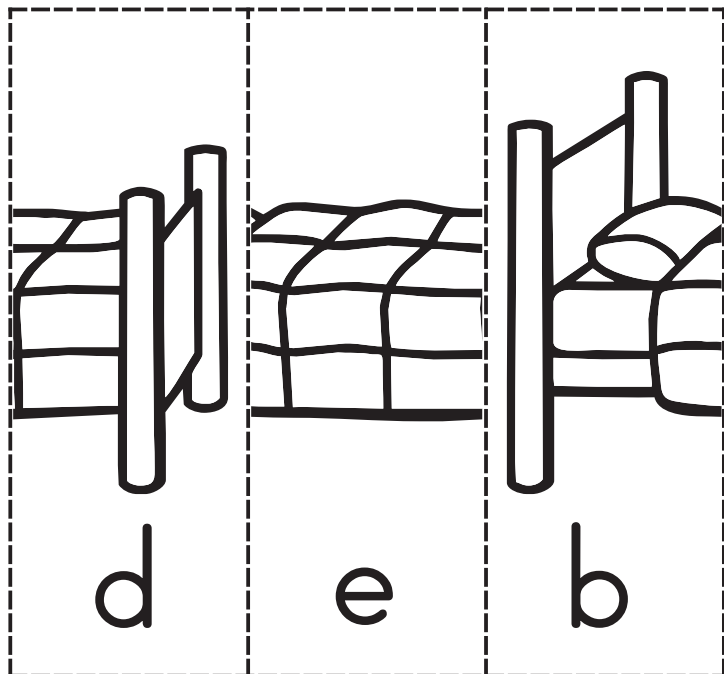
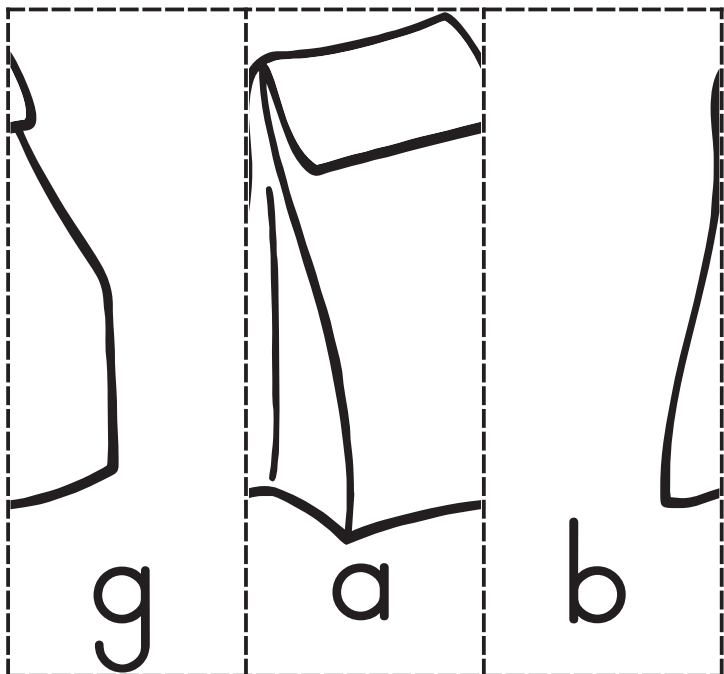

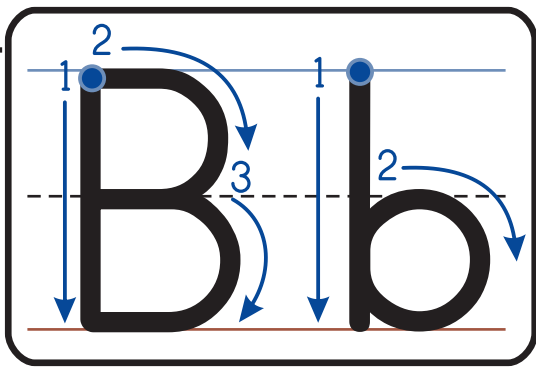

Name \_\_\_\_\_

## Letter Maze

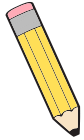

Help the boy get to the book by following the B-b-B-b pattern through the maze.



B	b	B	b	B	b	E
h	A	d	g	H	B	D
K	i	B	b	B	b	C
x	o	b	F	n	L	q
p	m	B	l	Q	y	k
s	J	b	a	r	M	z
N	f	B	b	B	w	O
v	c	l	G	b	e	j
S	t	P	u	B	b	B



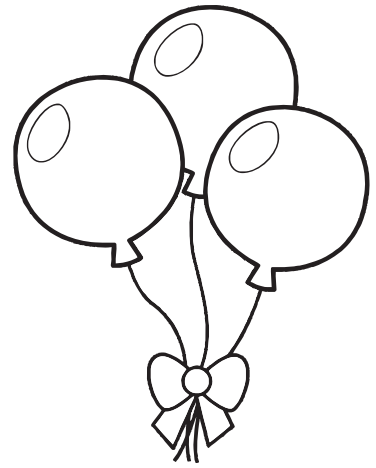
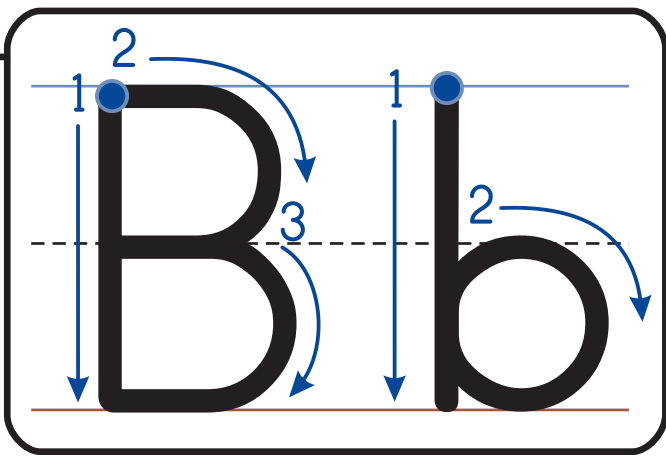

Name: \_\_\_\_\_

balloons

Follow the different Bb's through the maze.

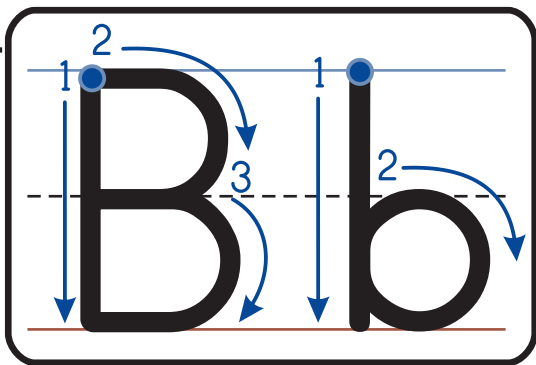

Name \_\_\_\_\_

## Hidden Letter



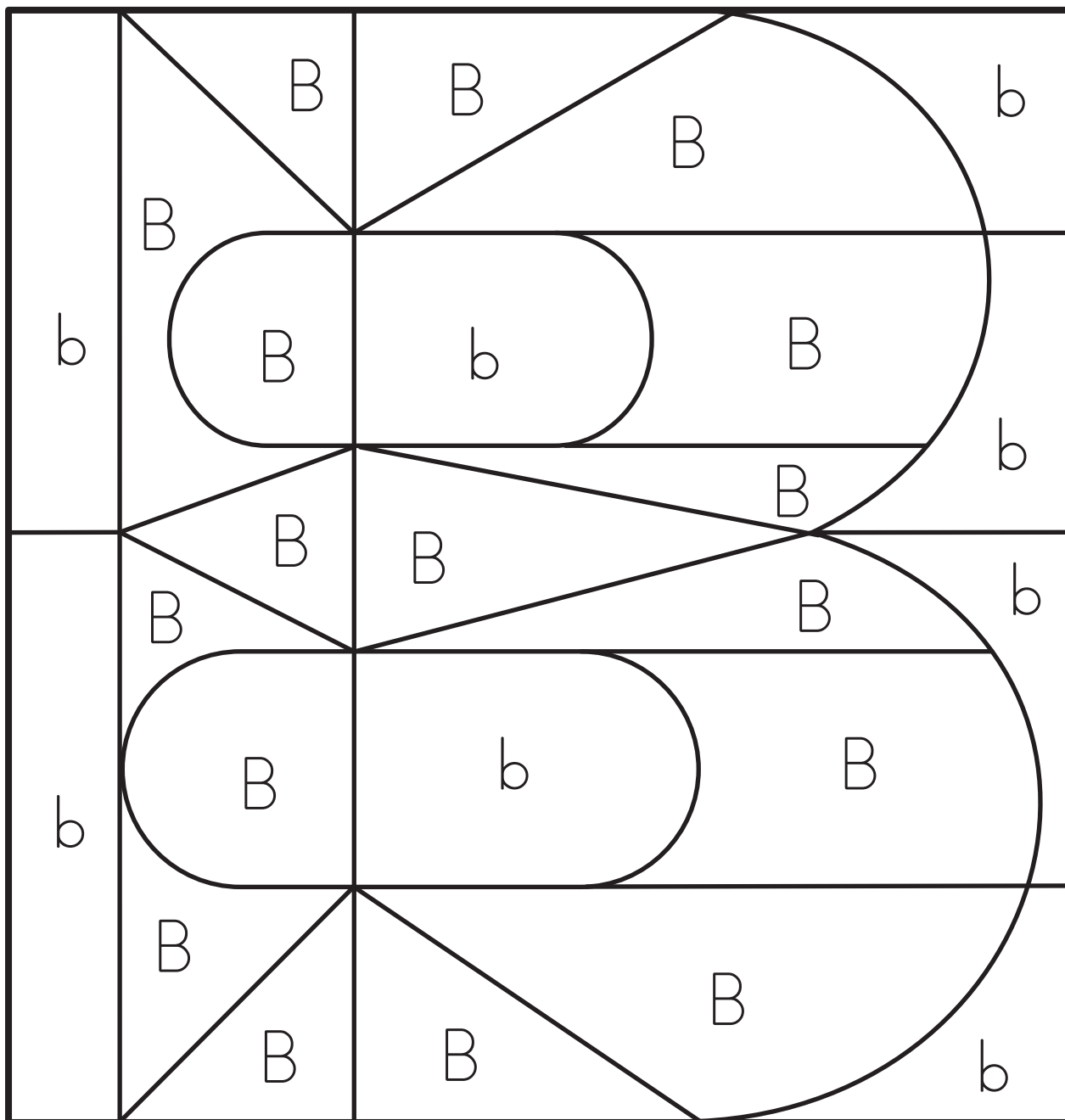

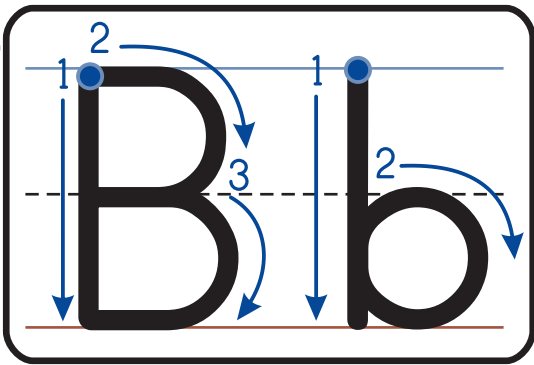
Name \_\_\_\_\_

## Hidden Letter

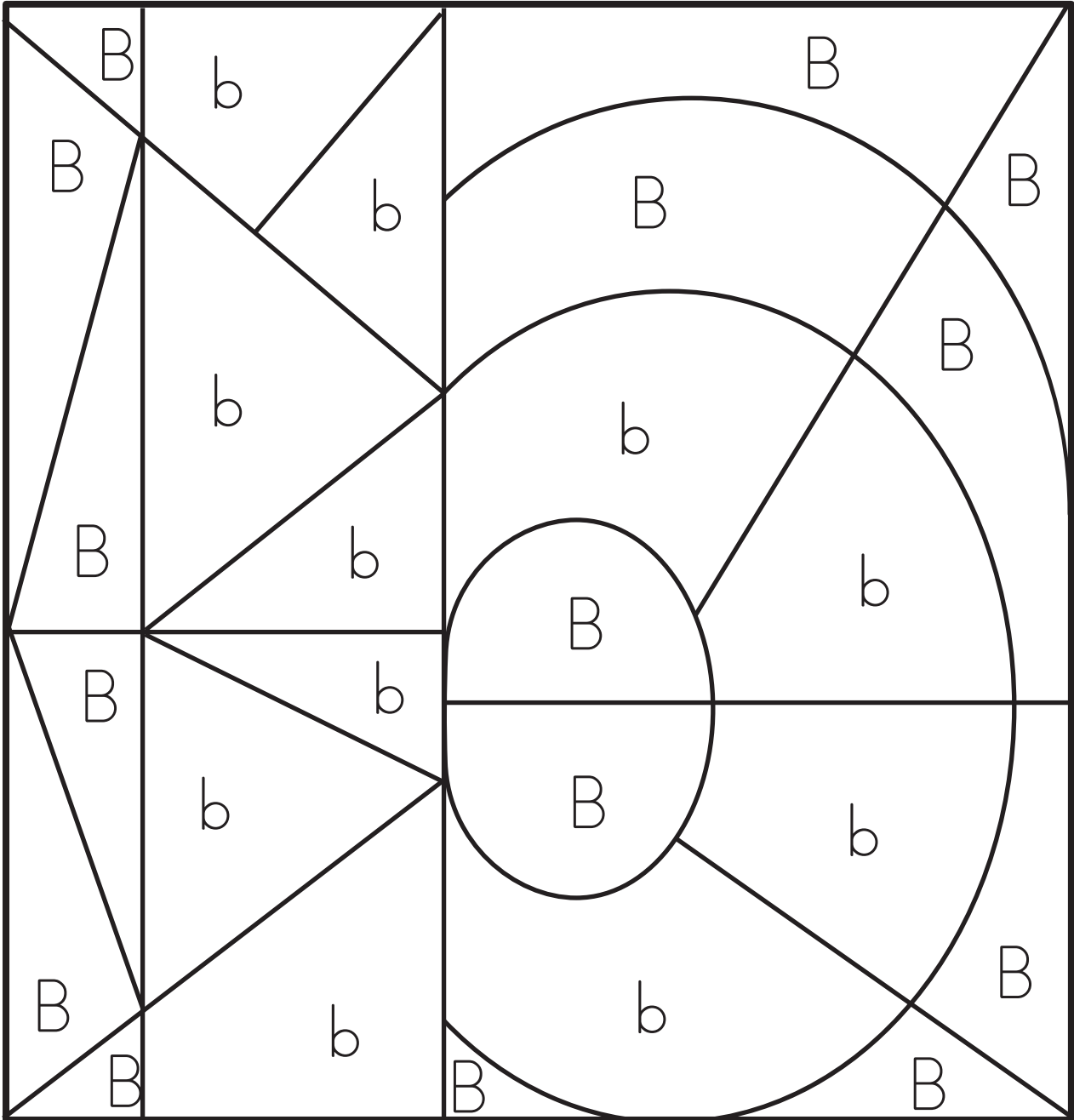

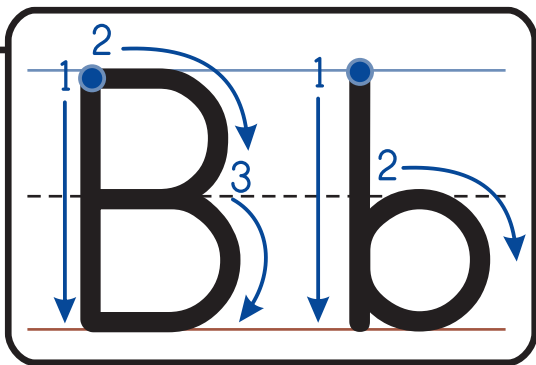

Name \_\_\_\_\_

## Beginning Sounds

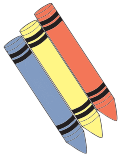

Color the pictures that begin with the Bb sound.





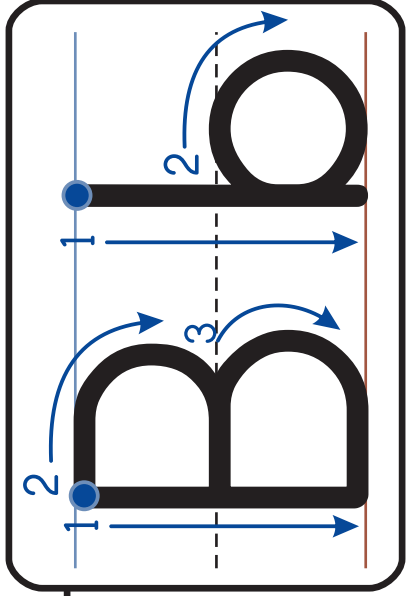

Name: \_\_\_\_\_

# Letter Find

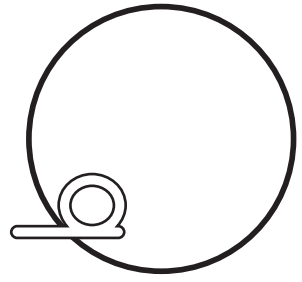
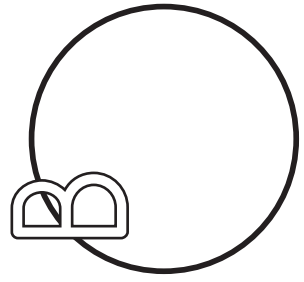
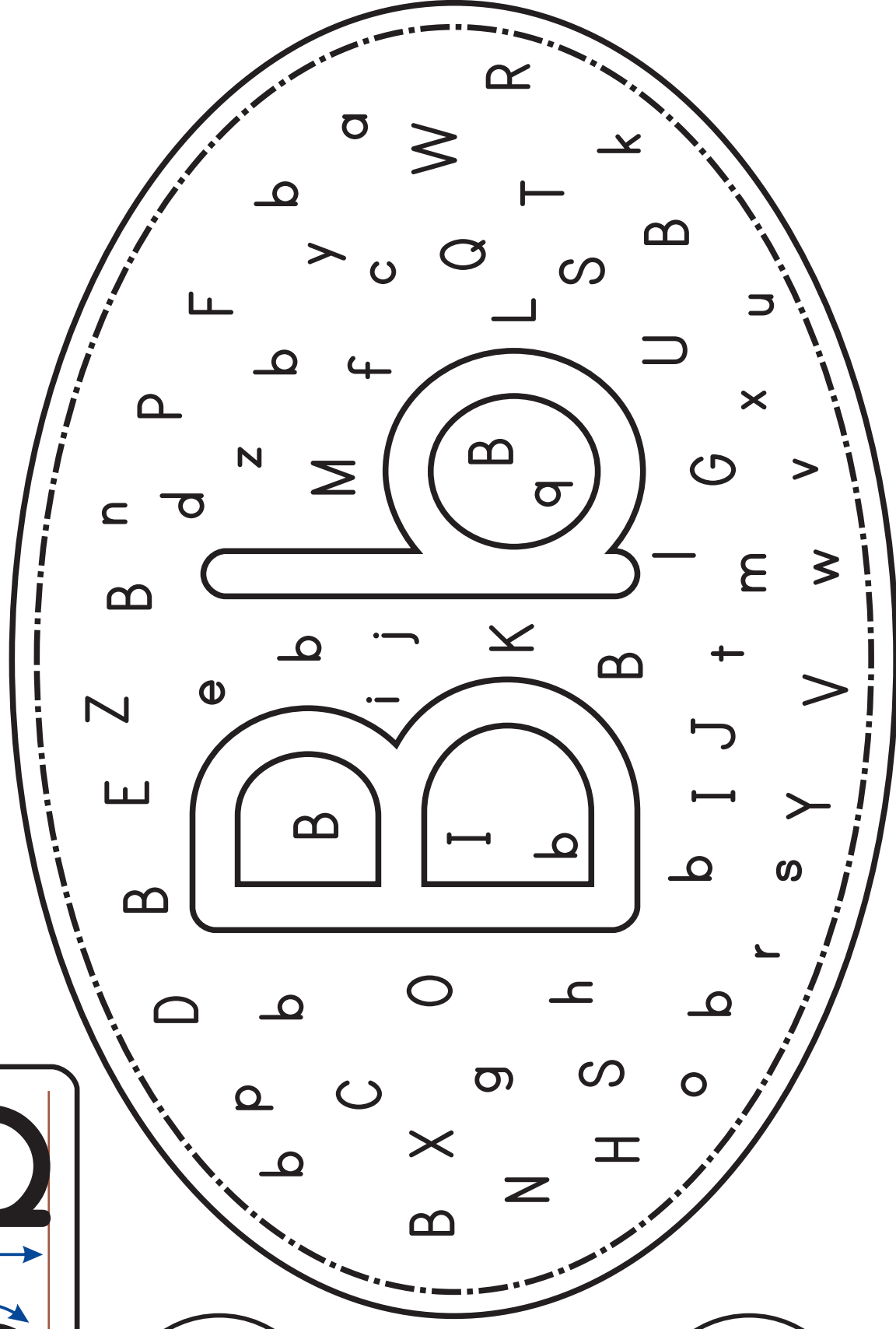

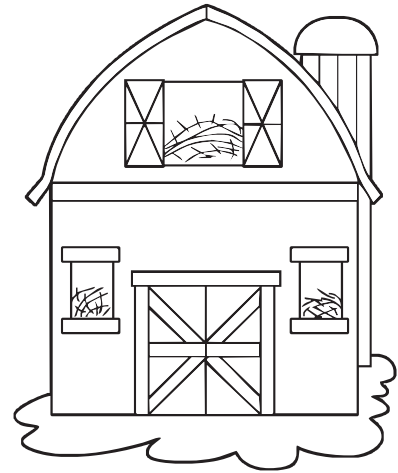
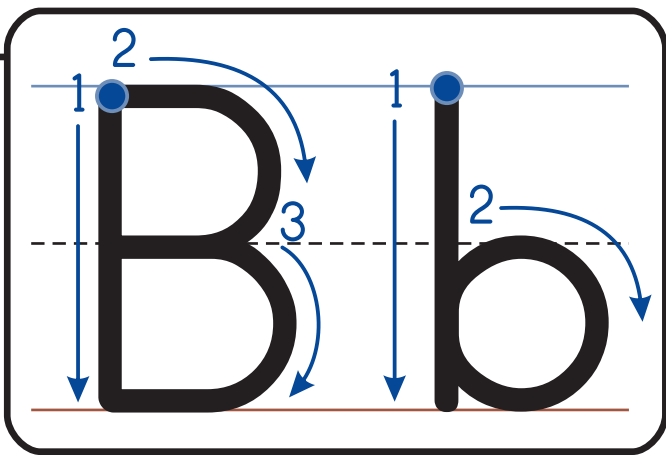

Name: \_\_\_\_\_

barn

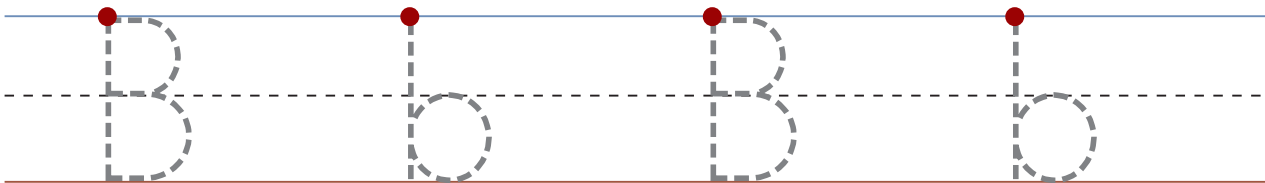
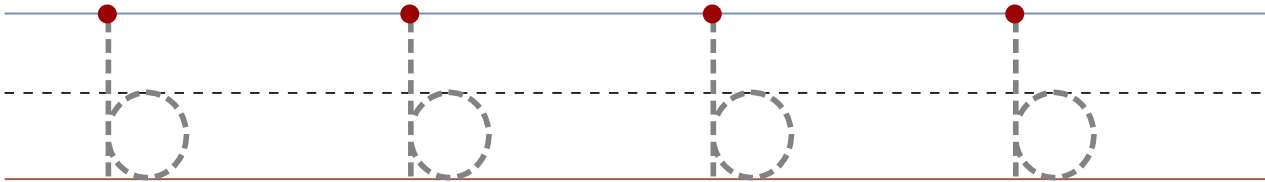
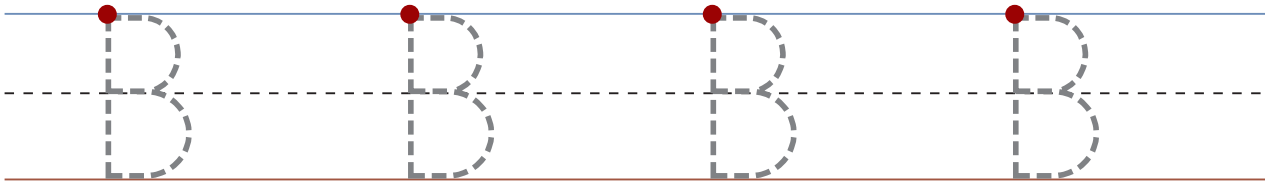
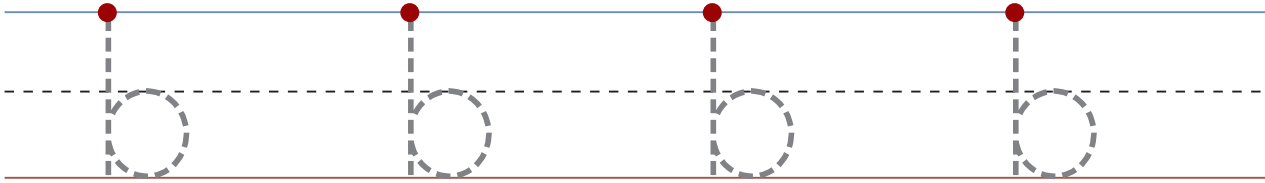
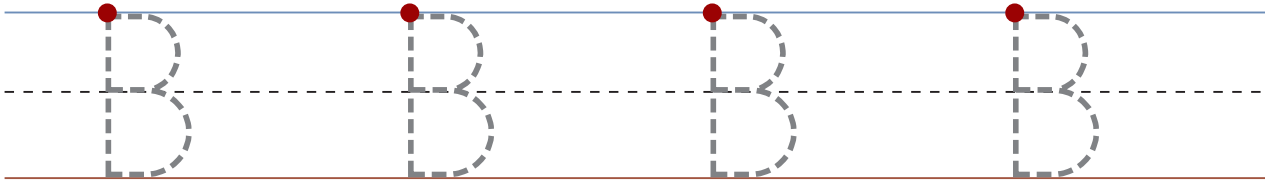

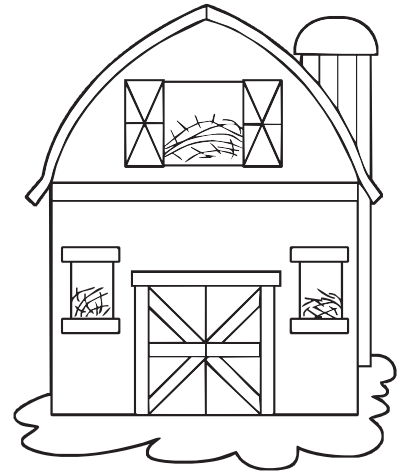
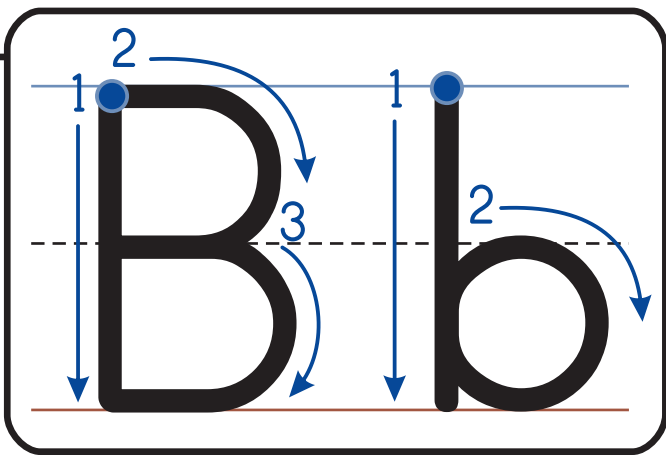

Name: \_\_\_\_\_

barn

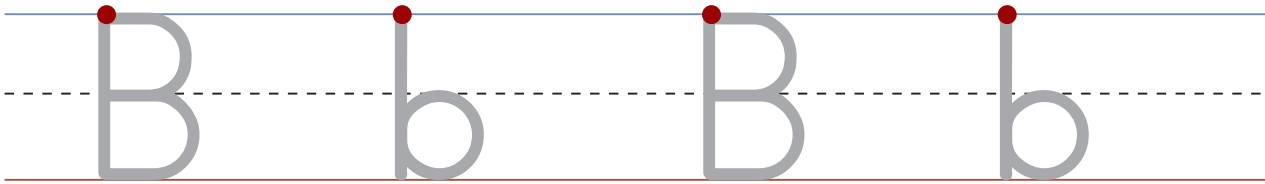
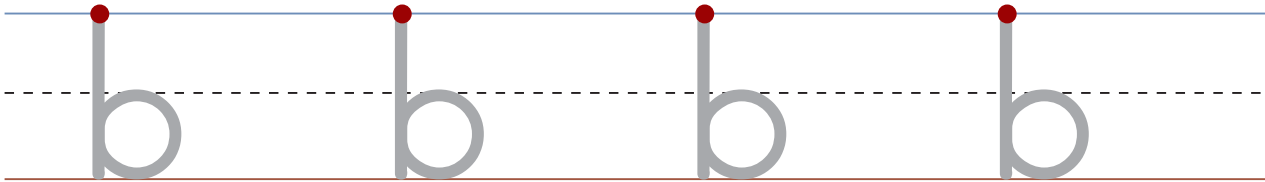
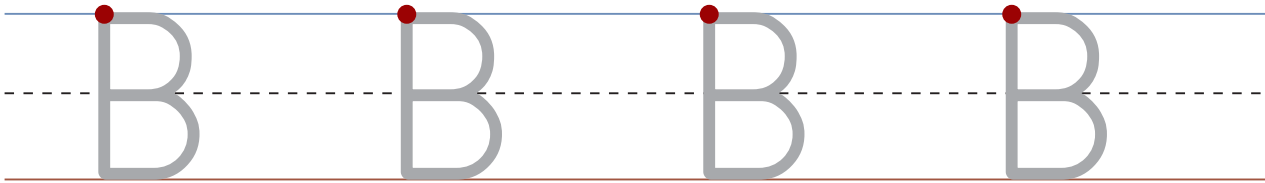
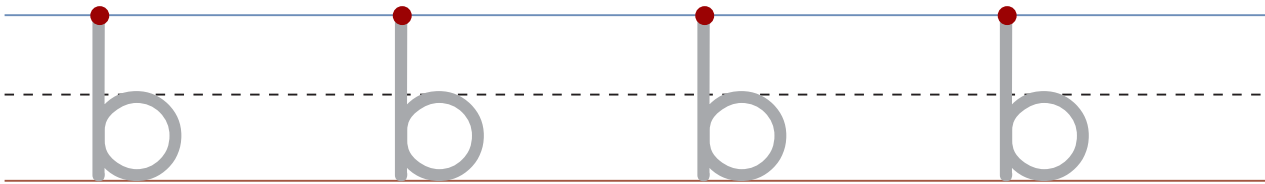
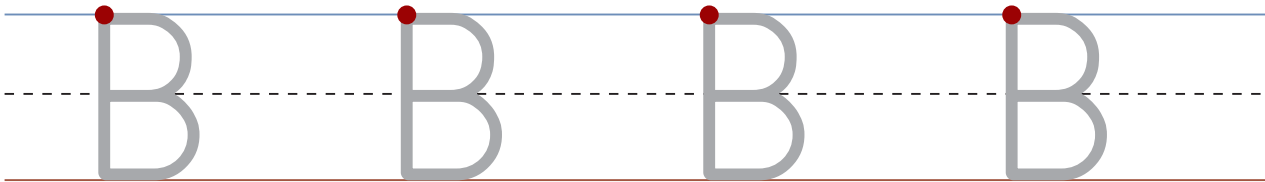

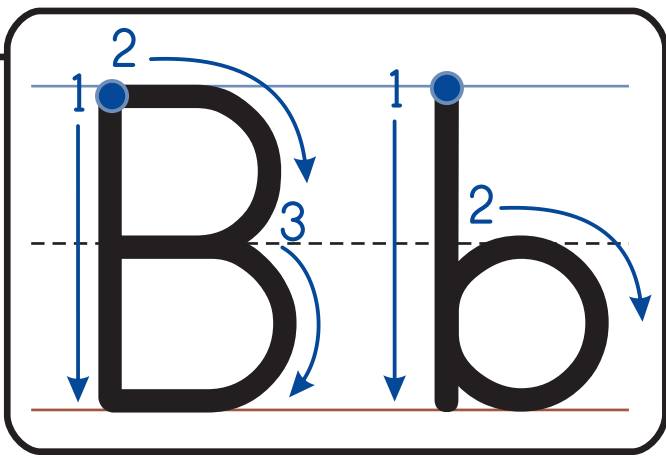

Name: \_\_\_\_\_

bath

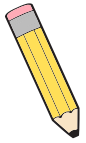

Trace B and b.

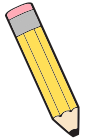
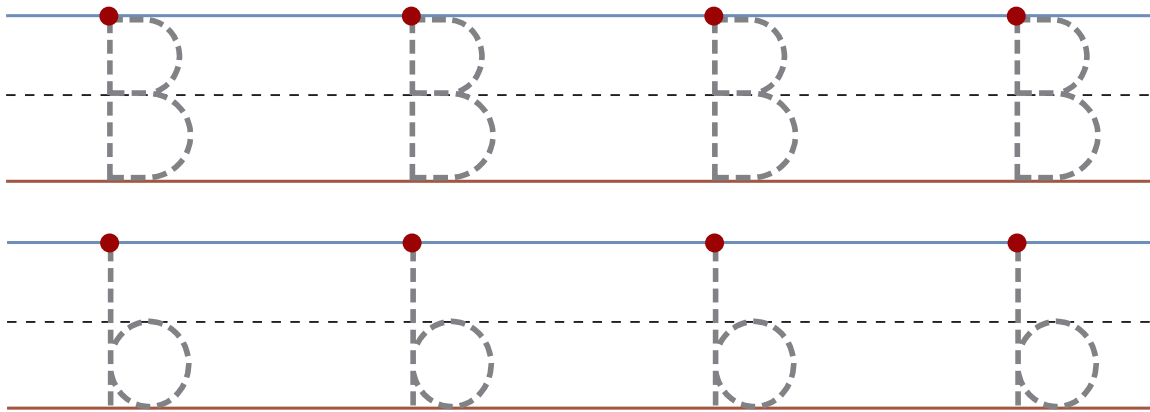

Write B and b in the boxes.



Cut and paste the B and b letter tiles.

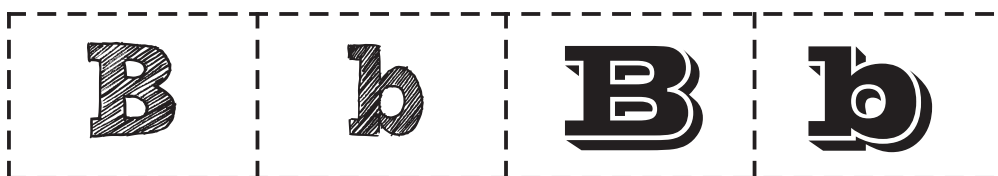

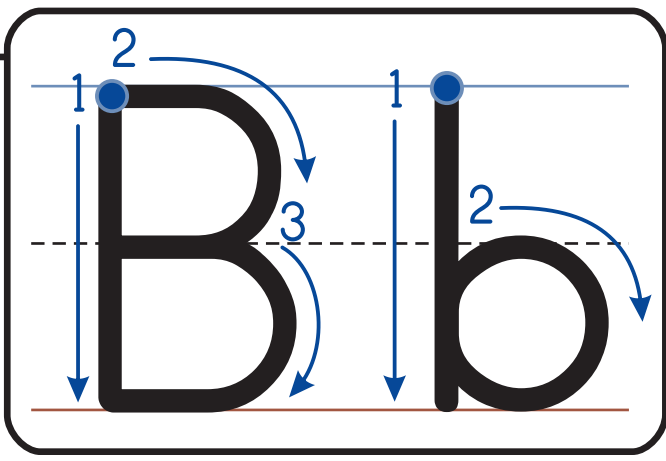

Name: \_\_\_\_\_

bath

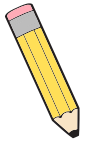

Trace B and b.

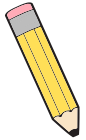
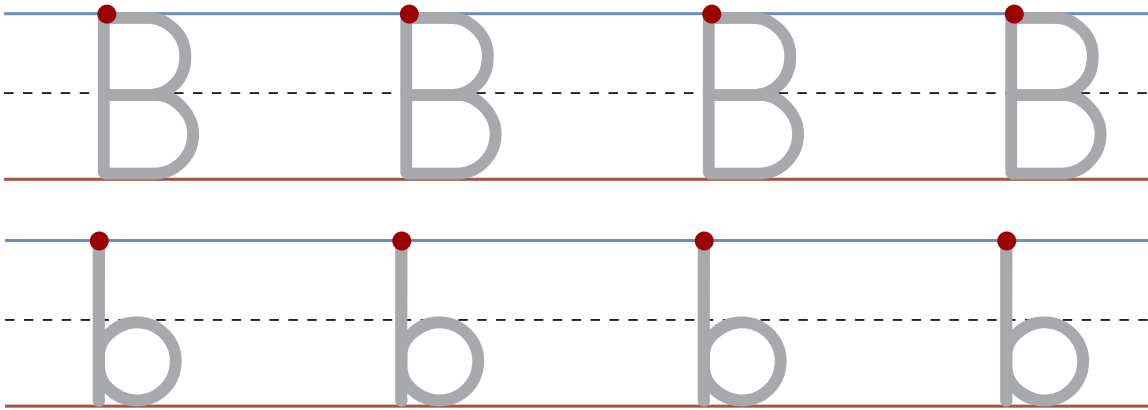

Write B and b in the boxes.

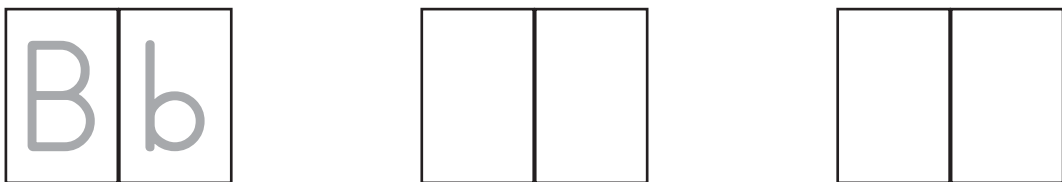

Cut and paste the B and b letter tiles.

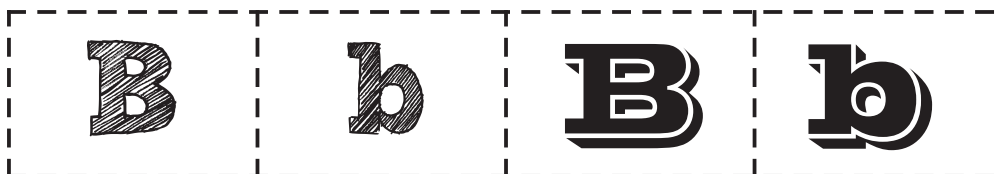

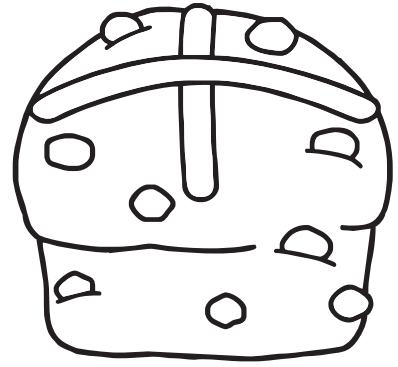
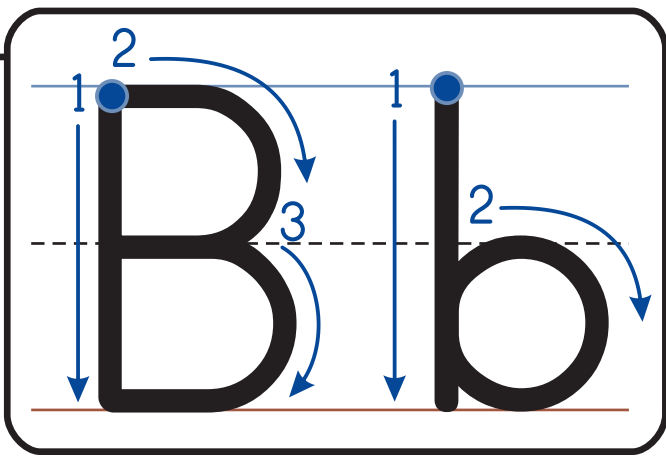

Name: \_\_\_\_\_

bun

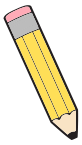

Trace B and b.

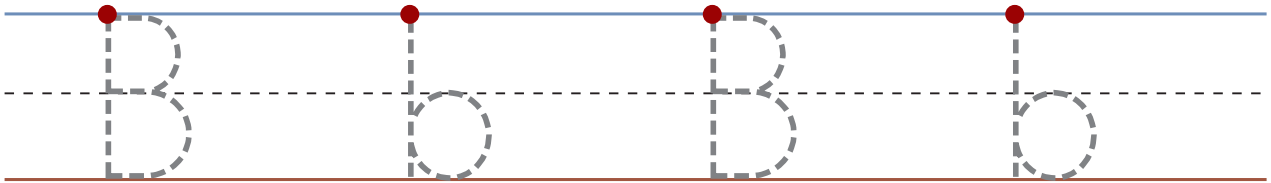

Cut and paste the pictures next to their beginning sounds.

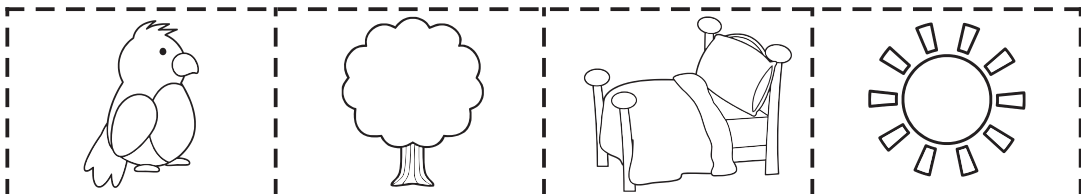
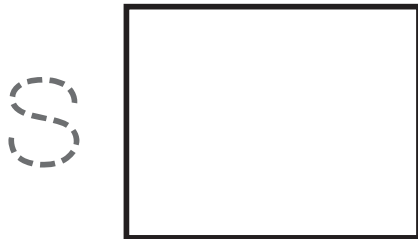
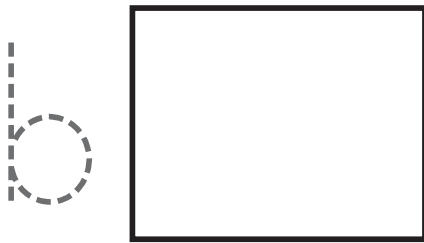

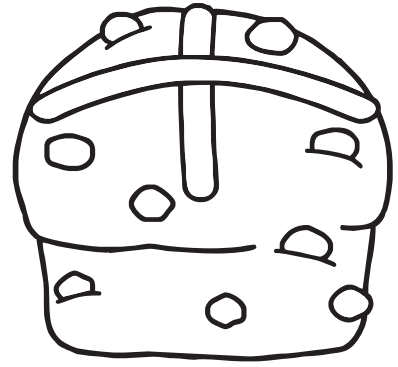
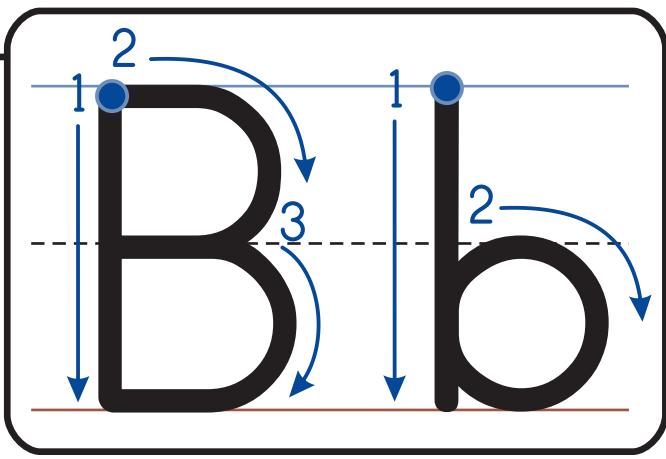

Name: \_\_\_\_\_

bun

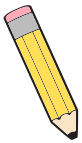

Trace B and b.

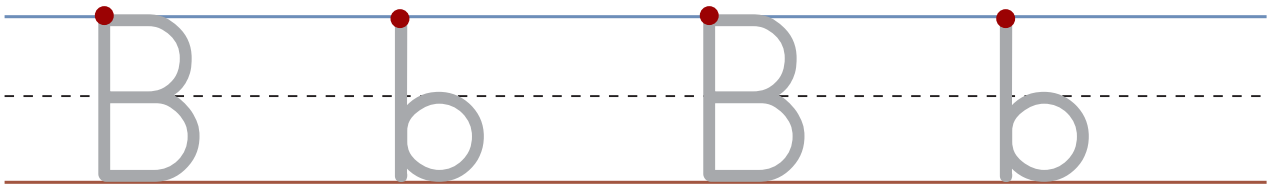

Cut and paste the pictures next to their beginning sounds.

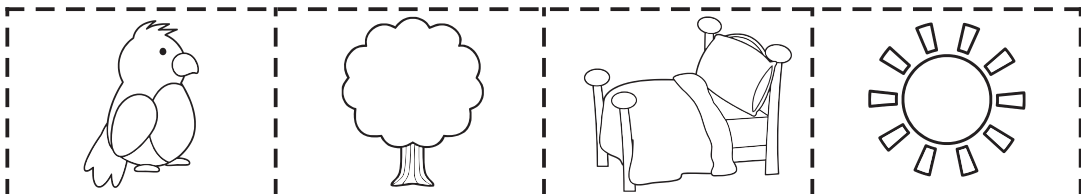
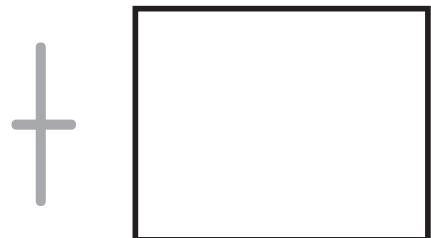
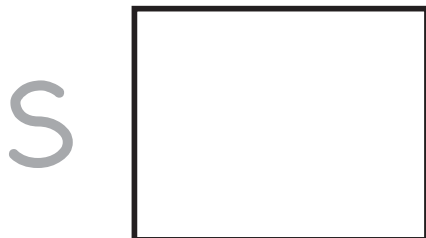
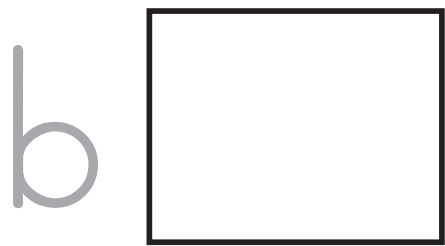
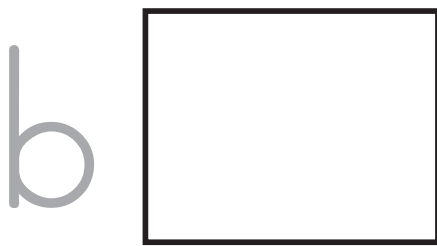

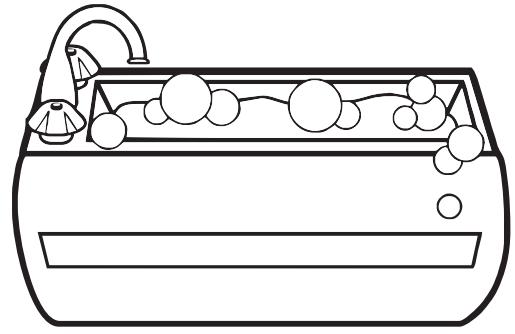
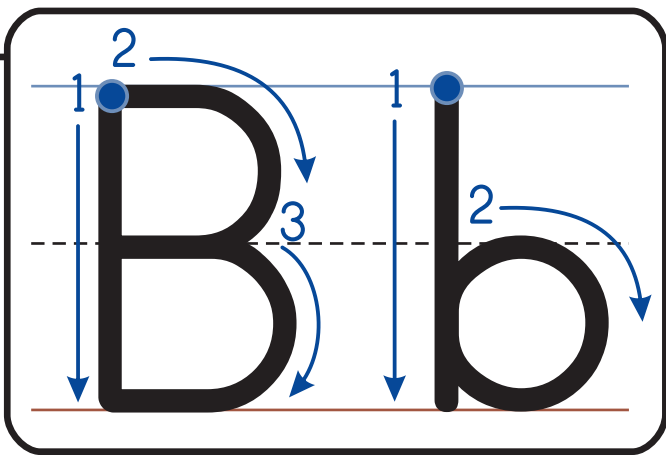

Name: \_\_\_\_\_

bathtub



Trace the words on the left. Color the pictures below, cut and paste them in the correct boxes. Write the words next to the pictures.

bag

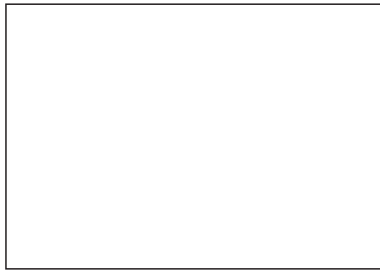

\_\_\_\_\_

\_\_\_\_\_

\_\_\_\_\_

bed

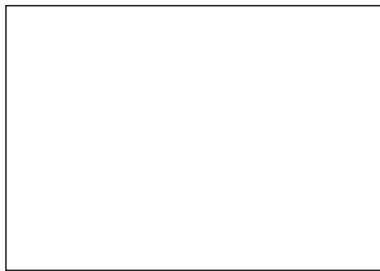

\_\_\_\_\_

\_\_\_\_\_

\_\_\_\_\_

bin



\_\_\_\_\_

\_\_\_\_\_

\_\_\_\_\_

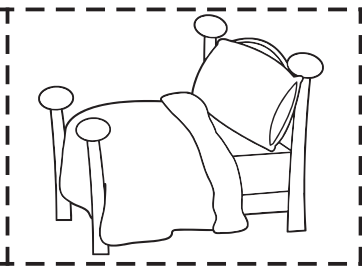
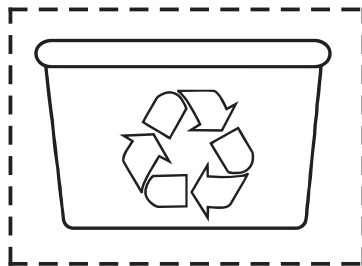



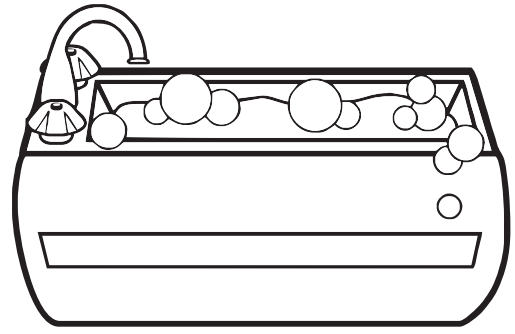
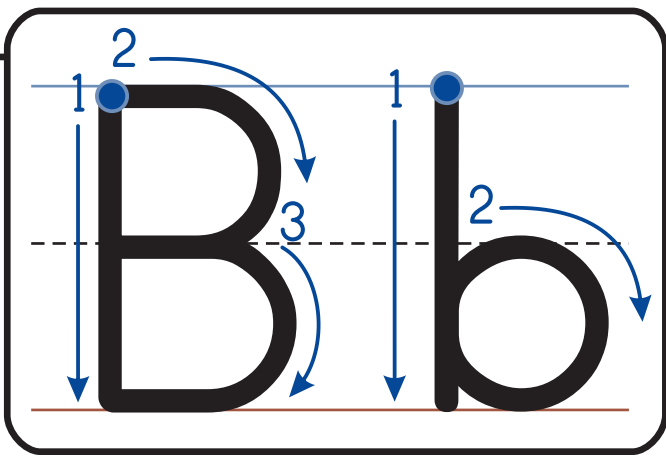

Name: \_\_\_\_\_

bathtub



Trace the words on the left. Color the pictures below, cut and paste them in the correct boxes. Write the words next to the pictures.

bag

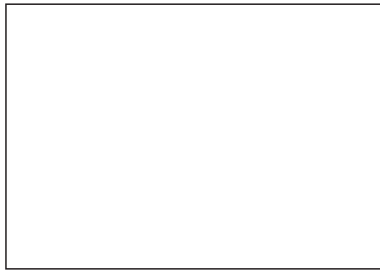

\_\_\_\_\_

bed

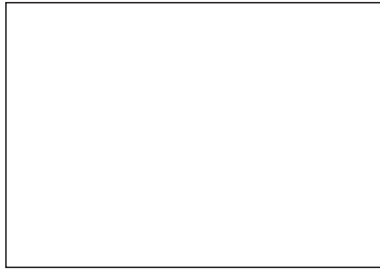

\_\_\_\_\_

bin



\_\_\_\_\_

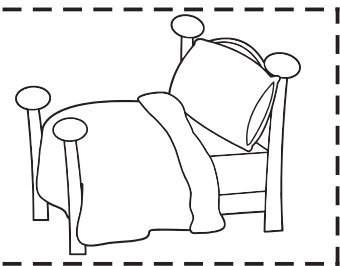
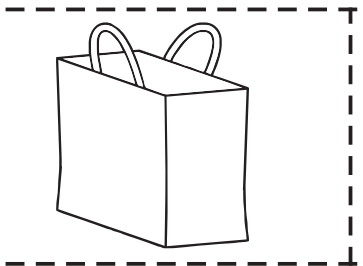
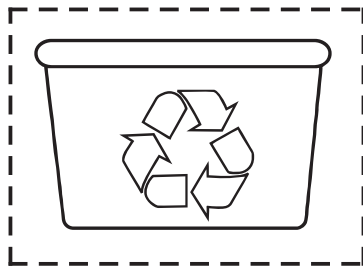

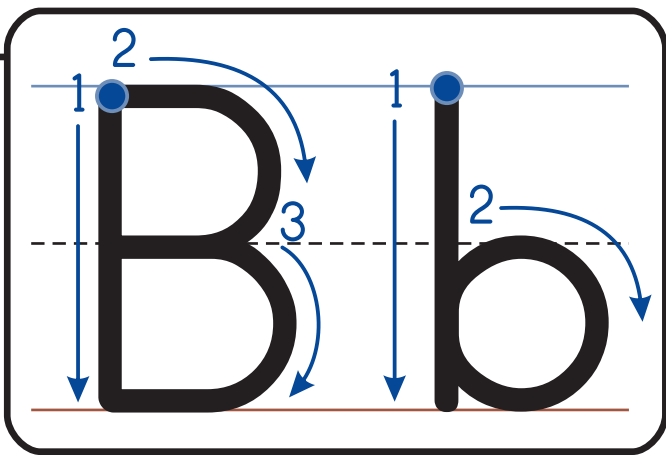

Name: \_\_\_\_\_

bed

Write each word on the lines, then join them to the correct pictures.

bat

\_\_\_\_\_

-----

\_\_\_\_\_

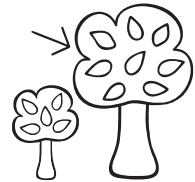

beg

\_\_\_\_\_

-----

\_\_\_\_\_

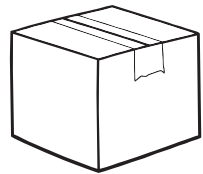

box

\_\_\_\_\_

-----

\_\_\_\_\_

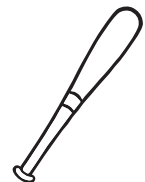

bus

\_\_\_\_\_

-----

\_\_\_\_\_



big

\_\_\_\_\_

-----

\_\_\_\_\_



bud

\_\_\_\_\_

-----

\_\_\_\_\_



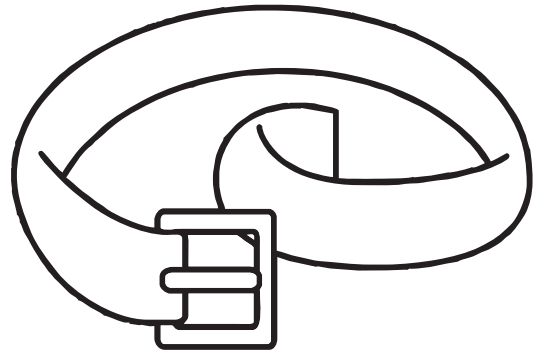
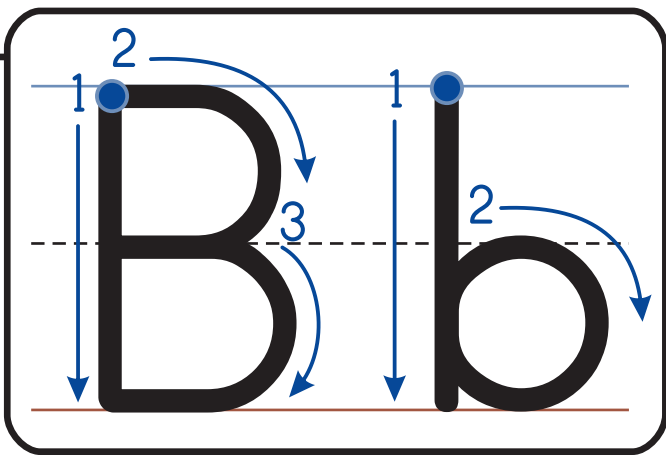

Name: \_\_\_\_\_

belt



Read the words. Underline b.

bib

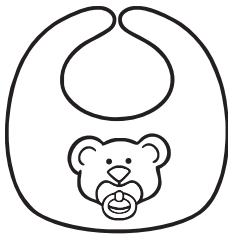

bad



bin

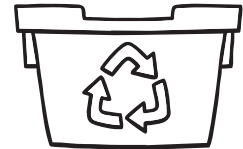

bun

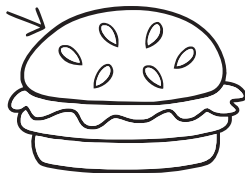

bug



bee

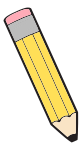
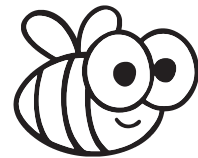

Underline B and b in the nursery rhyme.

Baa, baa, black sheep,  
Have you any wool?  
Yes, sir, yes, sir, three bags full.  
One for my master, one for my dame,  
And one for the little boy  
Who lives down the lane.

How many "Bb"s did you find? \_\_\_\_\_

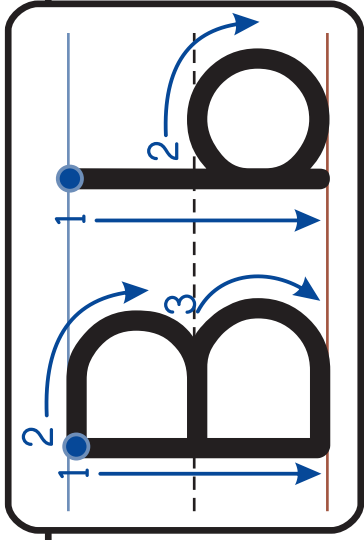

Name: \_\_\_\_\_

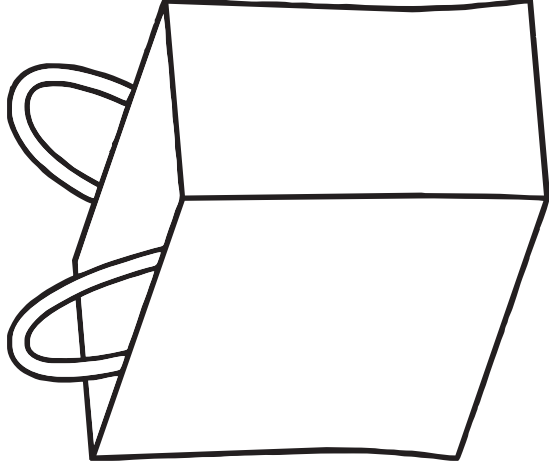

Read the following sentence:

I see a big bag.

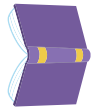

Write the sentence.

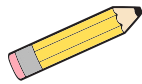

\_\_\_\_\_

\_\_\_\_\_

\_\_\_\_\_

Cut and paste the word cards in correct order.

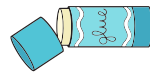

--	--	--	--	--

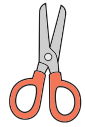

bag.	I	a	see	big
------	---	---	-----	-----

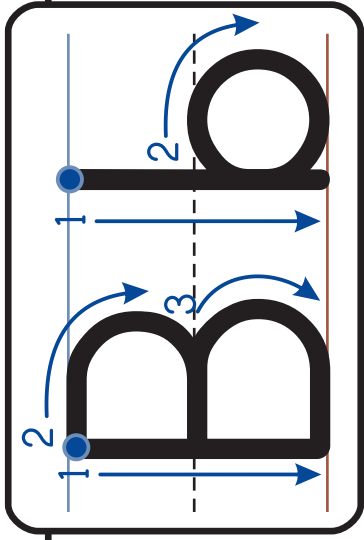

Name: \_\_\_\_\_

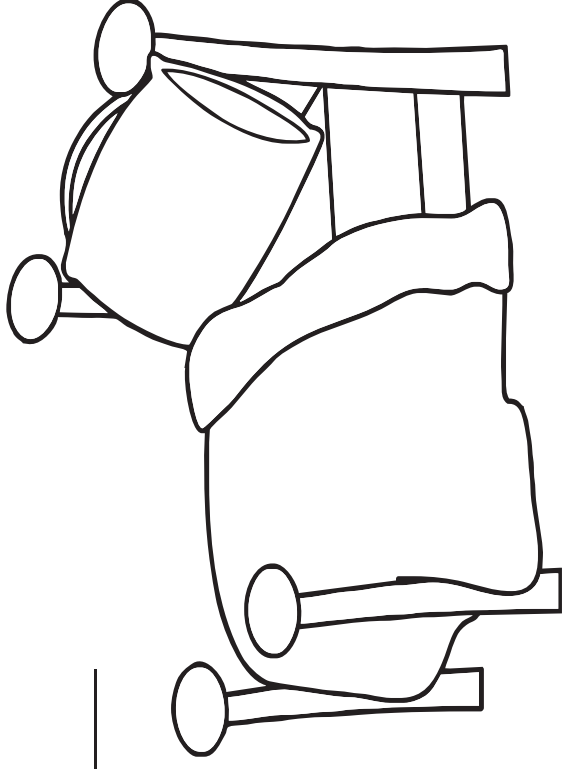

Read the following sentence:

I see a big bed.



Write the sentence.

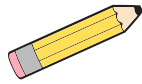

Cut and paste the word cards in correct order.

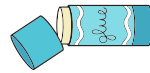

--	--	--	--	--

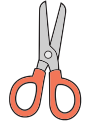

big	see	a	I	bed.
-----	-----	---	---	------

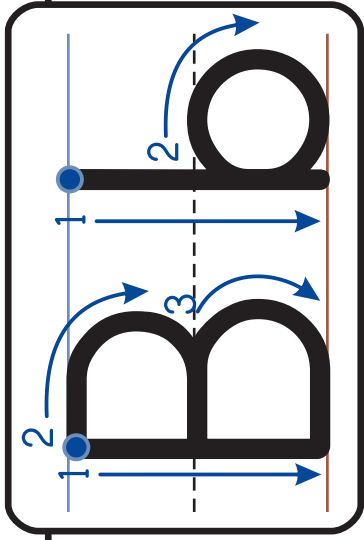

Name: \_\_\_\_\_

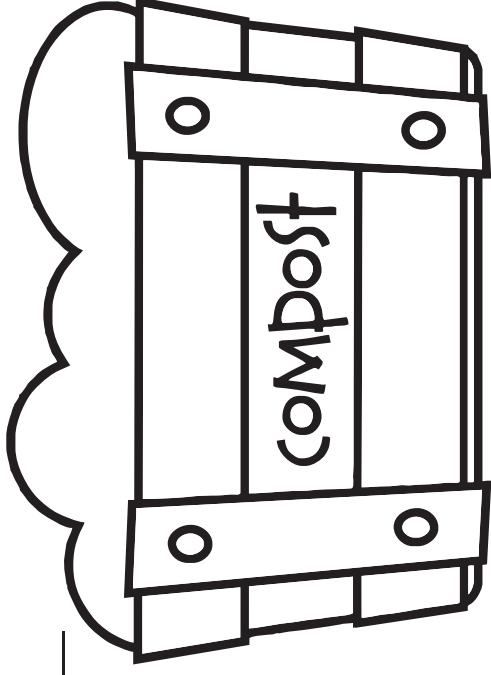

Read the following sentence:

I see a big bin.

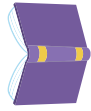

Write the sentence.

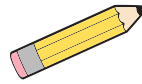

Cut and paste the word cards in correct order.

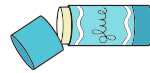

--	--	--	--	--



a	big	I	see	bin.
---	-----	---	-----	------

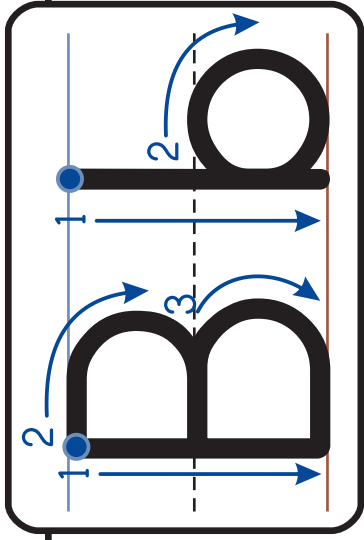

Name: \_\_\_\_\_

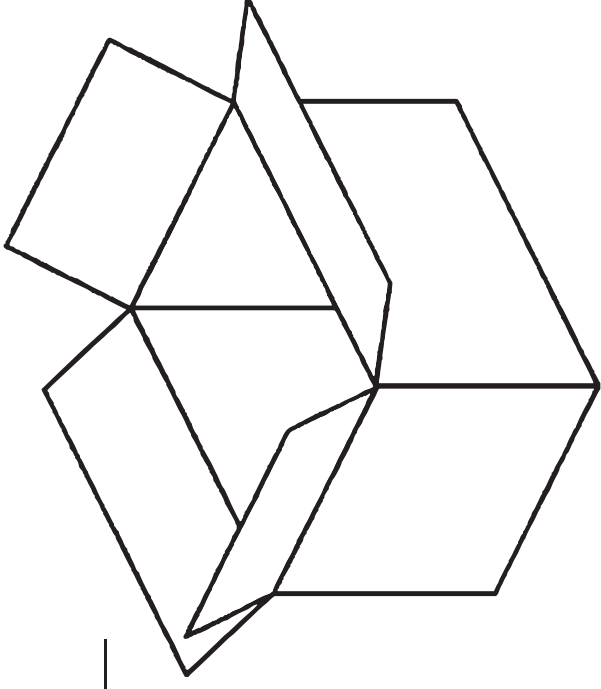

Read the following sentence:

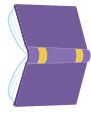

I see a big box.

Write the sentence.

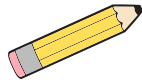

\_\_\_\_\_

\_\_\_\_\_

\_\_\_\_\_

Cut and paste the word cards in correct order.

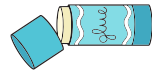

--	--	--	--	--

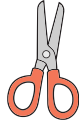

box.	big	I	see	a
------	-----	---	-----	---

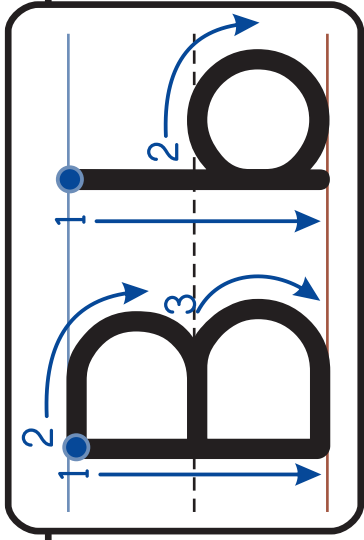

Name: \_\_\_\_\_

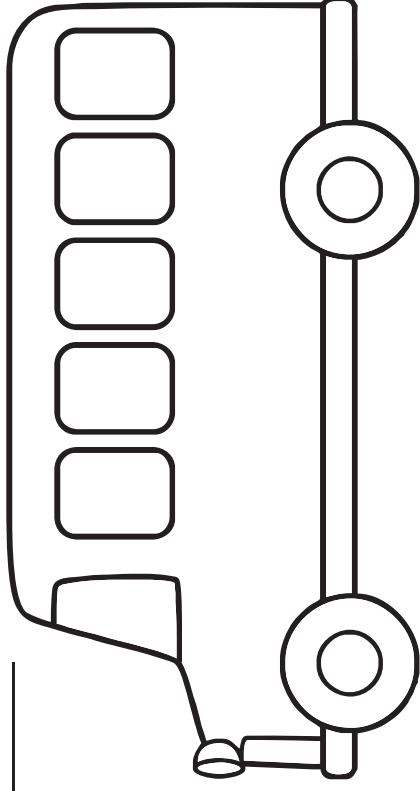

Read the following sentence:

I see a big bus.



Write the sentence.

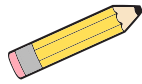

\_\_\_\_\_

\_\_\_\_\_

\_\_\_\_\_

Cut and paste the word cards in correct order.

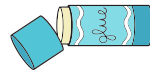

--	--	--	--	--

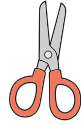

bus.	I	a	big	see
------	---	---	-----	-----



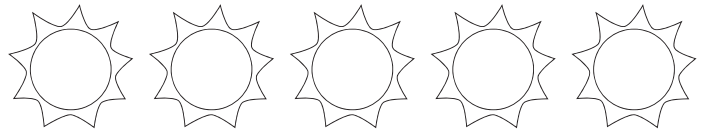
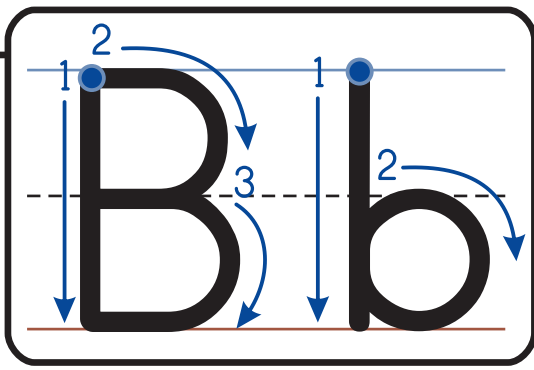

Color a sun each time you do this homework sheet.

1. What sound does Bb make?

2. Say the names of the following pictures. Circle the pictures if you hear the “Bb” sound. Is the sound at the beginning, in the middle or at the end of the word?

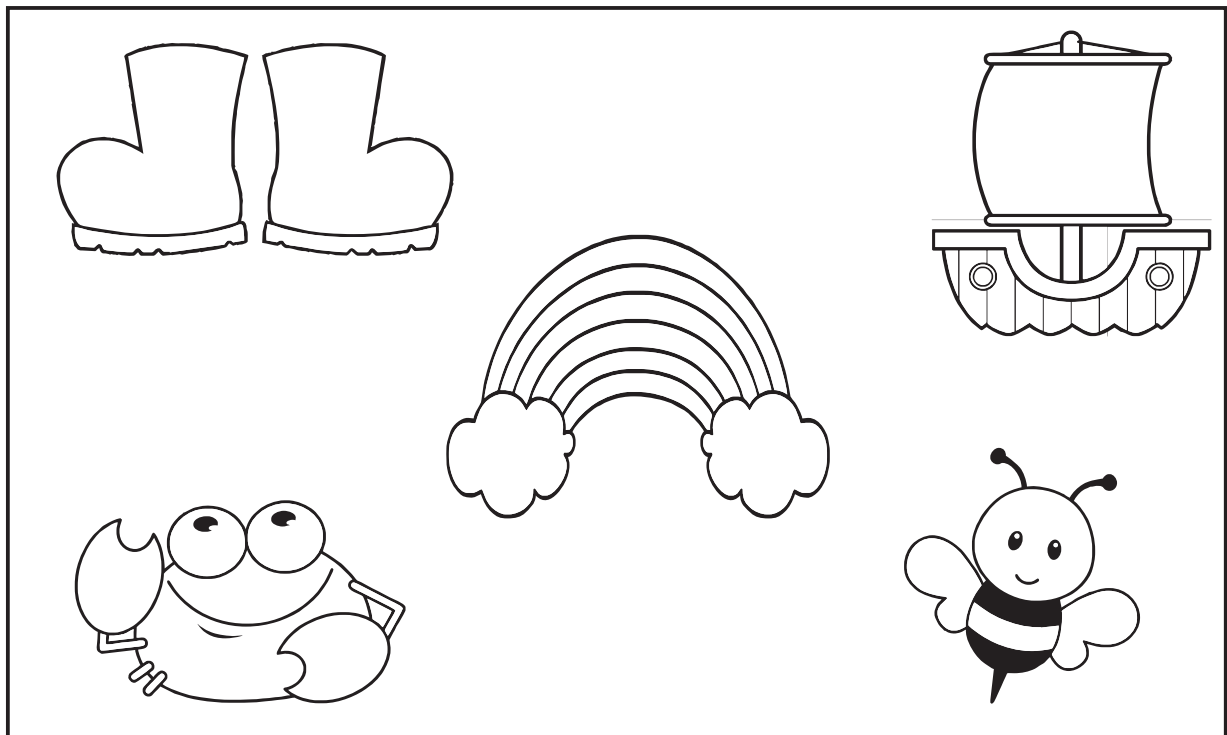

3. Think of other words that have the “Bb” sound.

4. Read the following words:

bat    bag    bad    bed    beg

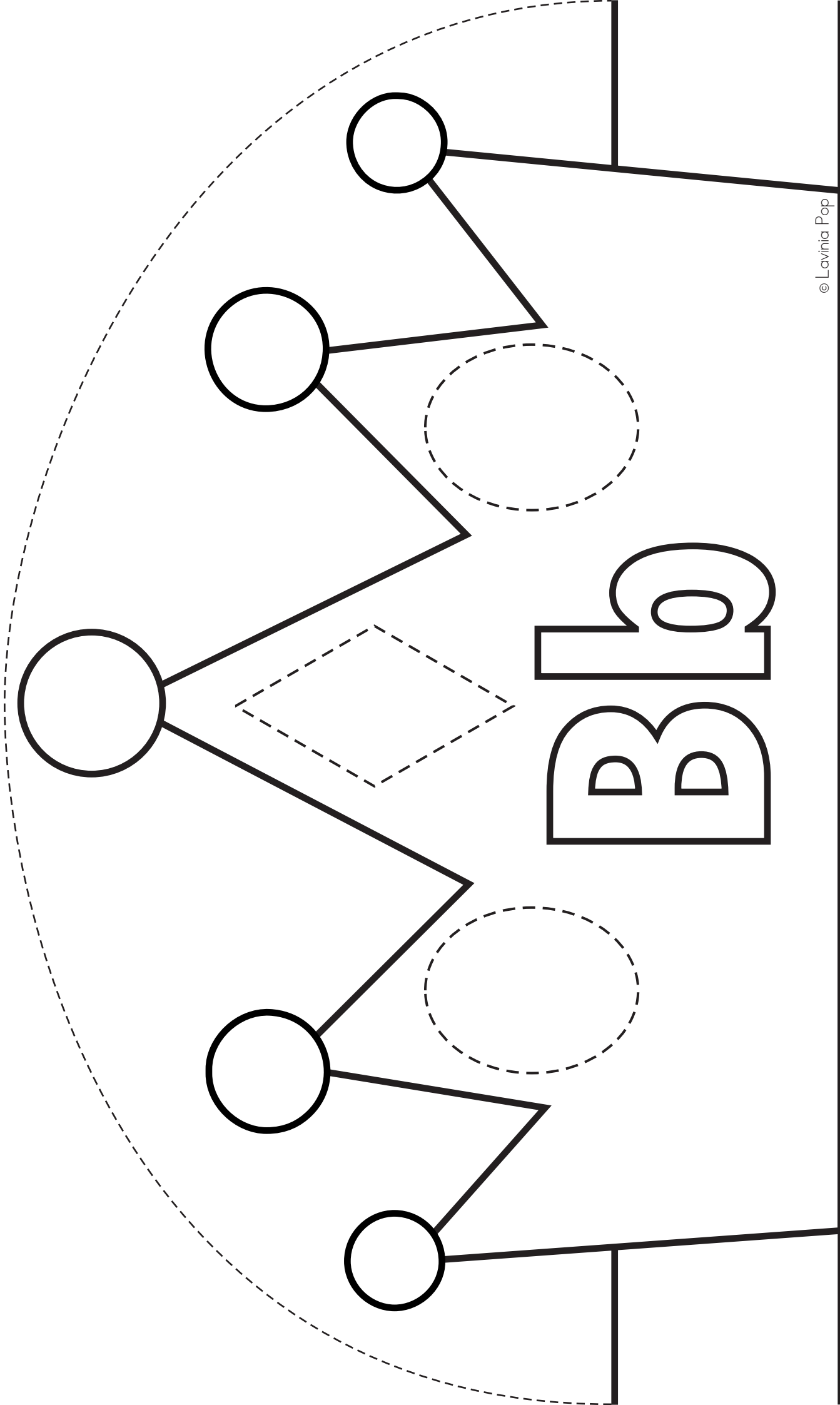

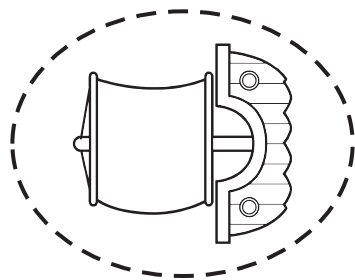
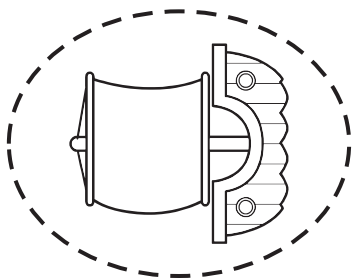
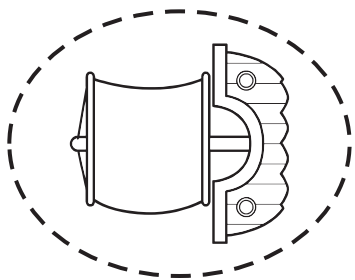
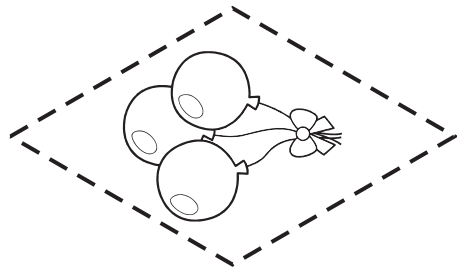
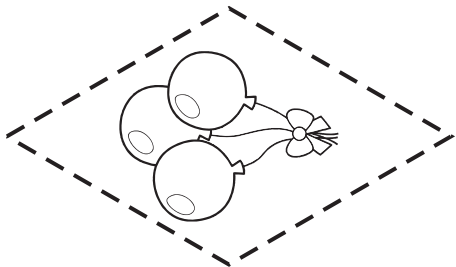
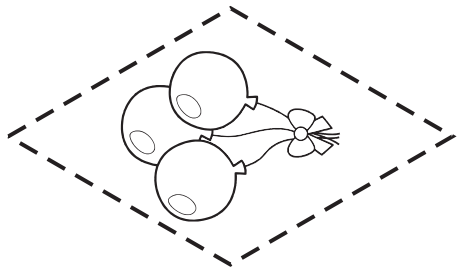
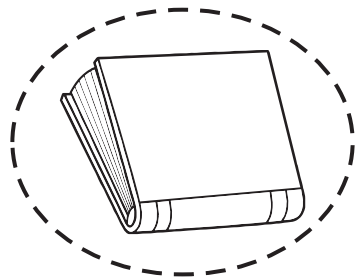
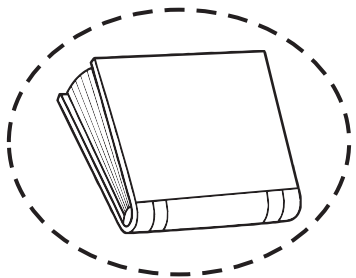
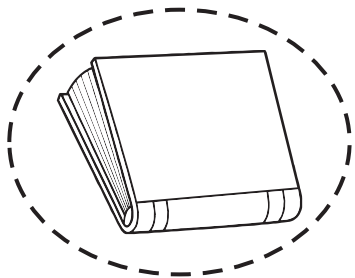
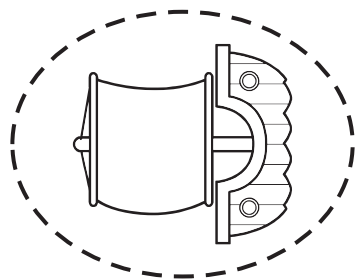
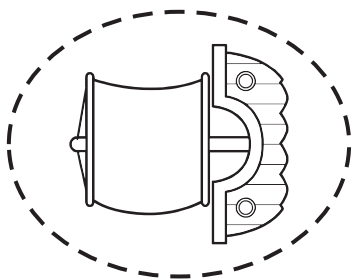
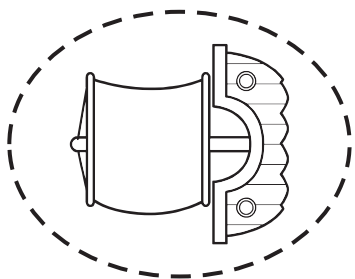
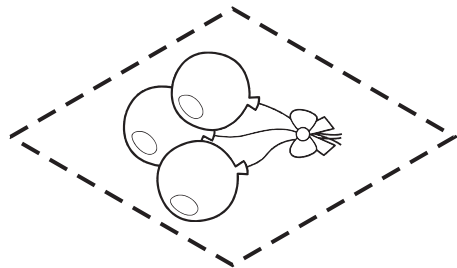
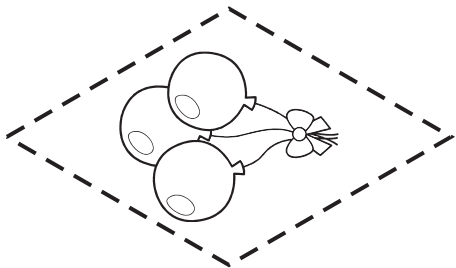
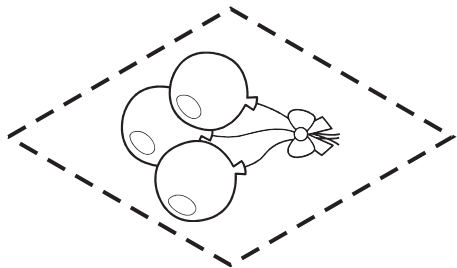
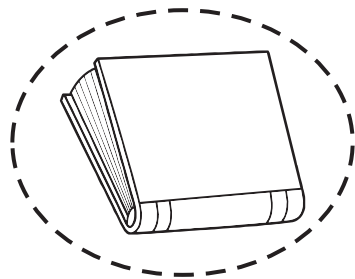
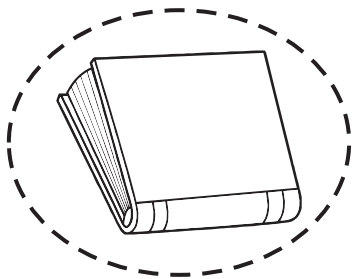
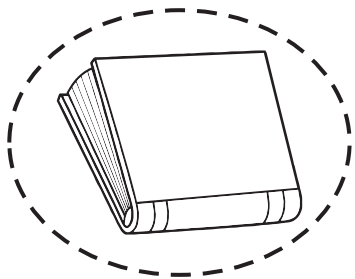

glue/staple

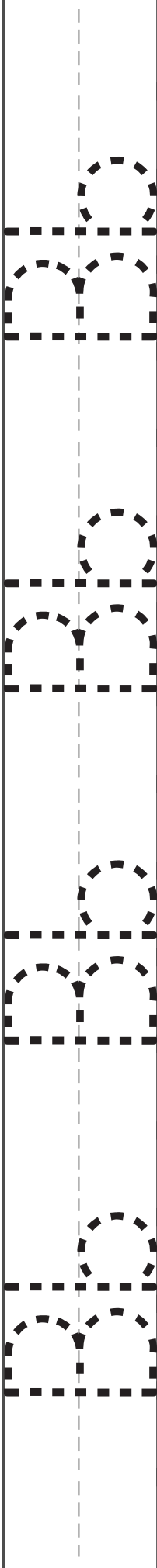

glue/staple

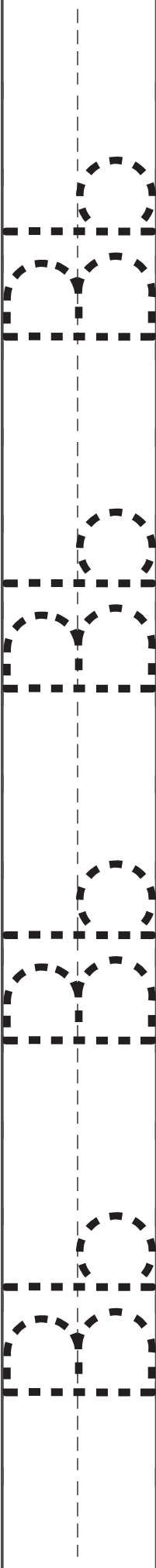

glue/staple

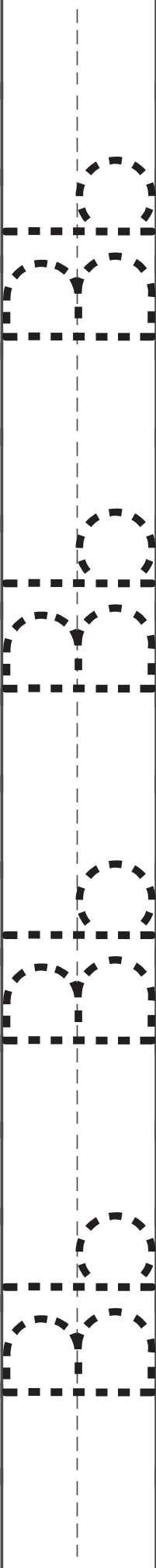

glue/staple

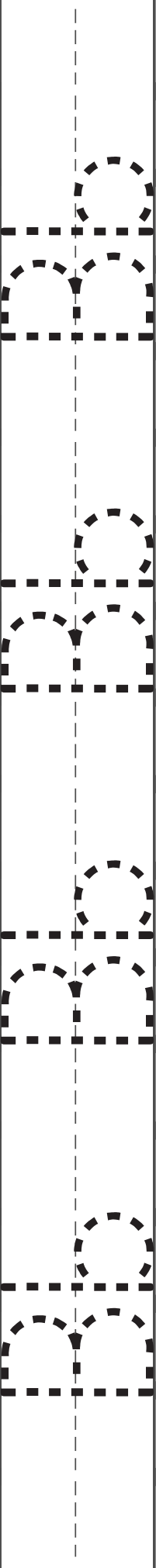

glue/staple

glue/staple

glue/staple

glue/staple

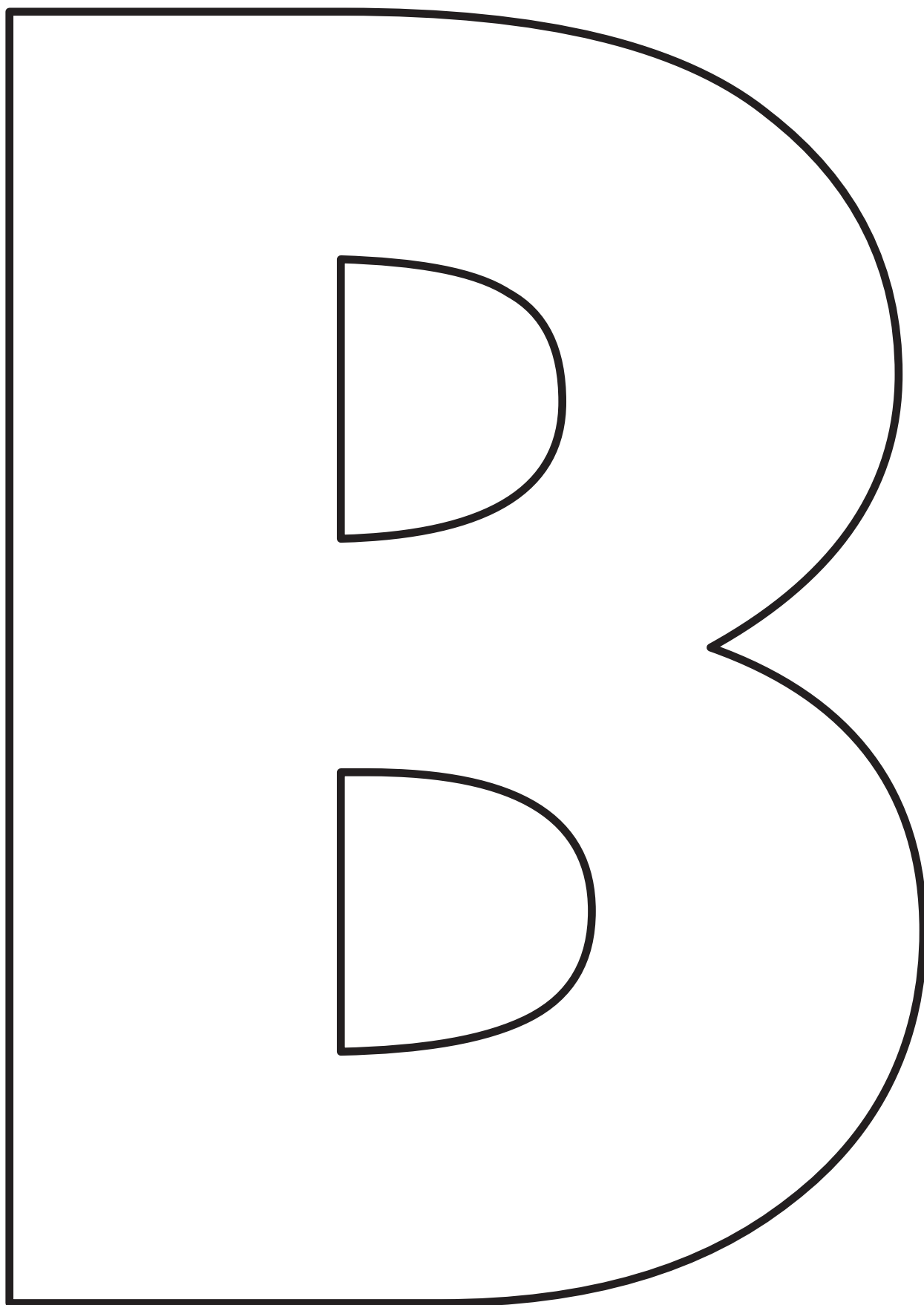

Alphabet Letter Craft: for craft ideas, please visit my blog [www.inmyworld.com.au/category/preschool](http://www.inmyworld.com.au/category/preschool)

